

TECHNICAL MANUAL

**SHIPBOARD DAMAGE
CONTROL MANUAL FOR**

DAMAGE CONTROL EQUIPMENT	4-1
STABILITY AND BUOYANCY	5-1
FIRE	6-1
SHORING	7-1
FLOODING	8-1

**LANDING CRAFT
UTILITY (LCU)**

NSN 1905-01-154-1191

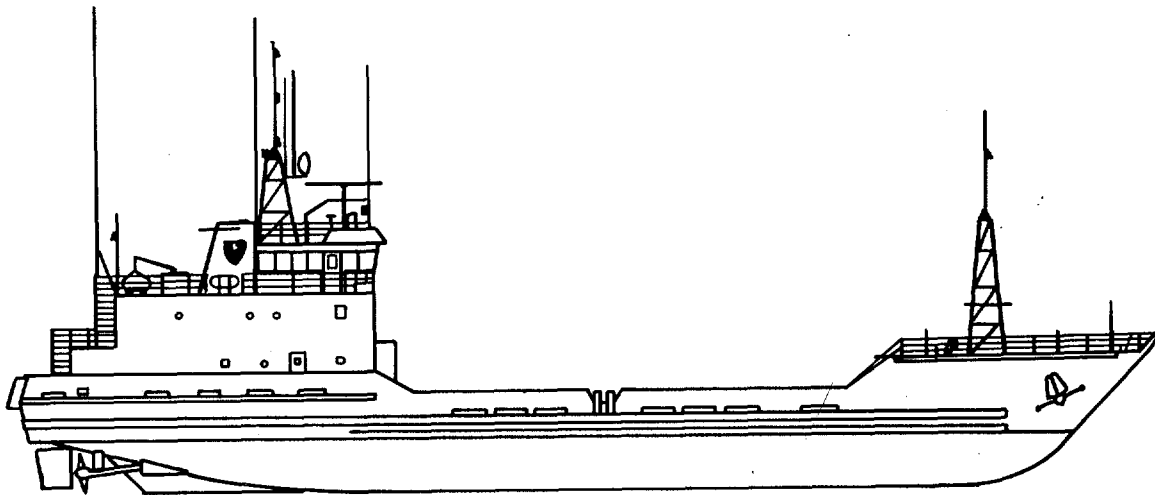

Approved for public release. Distribution is unlimited.

WARNING

Dangerous chemicals are used in this equipment. Serious injury or death may result from failure to observe safety precautions.

WARNING

Never work on energized electrical circuits. Serious injury or death may result if safety precautions are not observed.

WARNING

Investigation of structural damage by visual examination presents many difficulties and dangers. To do a thorough job, it will often be necessary to open one or more watertight doors or hatches. It is unwise to open any such closures in the vicinity of damage, and it should be done only after a thorough investigation by means of soundings, and after obtaining permission from higher authority whenever the situation permits. Serious personal injury is possible.

WARNING

Crew members must wear Oxygen Breathing Apparatus (OBA) when entering compartments that have not been tested as safe to enter. Serious personal injury could result.

WARNING

No watertight door, hatch, air fitting, oil fitting, cap, plug, scuttle, or manhole is to be opened until it is known definitely that the compartment on the other side is either completely dry, or so little flooded that opening the closure will not permit flooding to spread. Personal injury may result.

Shipboard Damage Control Manual for
 LANDING CRAFT UTILITY (LCU)
 NSN 1905-01-154-1191
 Approved for public release. Distribution is unlimited.

REPORTING ERRORS AND RECOMMENDING IMPROVEMENTS

You can help improve this manual. If you find any mistake or if you know of a way to improve the procedures, please let us know. Mail your letter, DA Form 2028 (Recommended Changes to Publications and Blank Forms), or DA Form 2028-2 located in the back of this manual direct to: Commander, U.S. Army Troop Support Command, ATTN: AMSTR-MCTS, 4300 Goodfellow Boulevard, St. Louis, MO 63120-1798. A reply will be furnished directly to you.

TABLE OF CONTENTS

	<u>PAGE</u>
CHAPTER 1	GENERAL INFORMATION
Section I	Damage Control Introduction 1-1
Section II	Objectives..... 1-2
Section III	Principal Characteristics..... 1-2
CHAPTER 2	EFFECTS OF DAMAGE
Section I	Types of Damage 2-1
Section II	Below Waterline Damage 2-3
Section III	Fire..... 2-3
Section IV	Corrective Measures for Control of Damage 2-4
CHAPTER 3	VENTILATION
Section I	Introduction..... 3-1
Section II	Ventilation of HALON-Fitted Spaces 3-1
Section III	Setting of Closures..... 3-1
CHAPTER 4	DAMAGE CONTROL EQUIPMENT
Section I	Introduction..... 4-1
Section II	Damage Control Equipment - General Description..... 4-1
Section III	Damage Control Equipment on the LCU 4-1
Section IV	Life Jackets..... 4-2
Section V	Sound-Powered Telephones 4-3
Section VI	LS-519A/SIC Intercommunication System 4-6
Section VII	General Alarm System..... 4-7

TABLE OF CONTENTS (Continued)

CHAPTER 5	STABILITY AND BUOYANCY	<u>PAGE</u>
Section I	Introduction.....	5-1
Section II	Definitions.....	5-1
Section III	Stability Characteristics.....	5-5
Section IV	Damage Resistance Characteristics of the LCU.....	5-5
Section V	Measures to Resist Flooding Before Damage.....	5-7
Section VI	Effects of Damage.....	5-11
Section VII	Stability Required and Stability Available.....	5-12
Section VIII	Measures to Safeguard Stability.....	5-13
Section IX	Standard Conditions of Loading.....	5-17
Section X	Liquid Loading Diagram.....	5-18
Section XI	Curve of Righting Levers.....	5-19
Section XII	Trim and Stability Booklet and Damage Stability Booklet.....	5-24
CHAPTER 6	FIRE	
Section I	Introduction.....	6-1
Section II	Chemistry and Physics of Fire.....	6-1
Section III	Classes of Fire.....	6-1
Section IV	Products of Combustion.....	6-2
Section V	Fire Hazards of Materials.....	6-3
Section VI	Extinguishing Agents.....	6-6
Section VII	Portable Fire Extinguishers.....	6-10
Section VIII	Operation of Fire Extinguishers.....	6-10
Section IX	Basics of Fighting Fire.....	6-12
Section X	LCU Fire Main.....	6-14
Section XI	Firefighting Equipment.....	6-17
Section XII	HALON Systems.....	6-19
Section XIII	Fire Protection System.....	6-19
Section XIV	Smoke Clearance.....	6-22
Section XV	Precautions in Ventilating.....	6-23
Section XVI	Use of Portable Ventilating Blowers.....	6-23
CHAPTER 7	SHORING	
Section I	Shoring - Introduction.....	7-1
Section II	Considerations for the Use of Shoring.....	7-1
Section III	Methods of Shoring.....	7-2
Section IV	Materials for Shoring.....	7-3
Section V	Preparing Shoring Material.....	7-4
Section VI	Application of Shoring.....	7-5

TABLE OF CONTENTS (Continued)

CHAPTER 8	FLOODING	<u>PAGE</u>
Section I	Flooding Load	8-1
Section II	Investigating Flooding Damage.....	8-2
Section III	Methods of Repairing Holes	8-5
Section IV	Quick-Sealing Leaks and Cracks.....	8-8
Section V	Strengthening Beams and Frames.....	8-9
Section VI	Repairing Pipe Lines.....	8-10
Section VII	Damage Control Metallic Pipe and General Repair Kit (Plastic)	8-18
CHAPTER 9	ELECTRICAL POWER AND LIGHTING	
Section I	General Information	9-1
Section II	Normal Electrical Power.....	9-1
Section III	Power Distribution.....	9-1
Section IV	Emergency Electrical Power	9-3
Section V	Emergency Power Operation	9-3
Section VI	Emergency Lights	9-7
APPENDIX A	REFERENCES.....	A-1
GLOSSARY	Glossary-1
INDEX	Index-1

CHAPTER 1

GENERAL INFORMATION

SDC FIXES SHALL BE USED ONLY IN COMBAT OR OTHER EMERGENCY CONDITIONS AT THE DISCRETION OF THE VESSEL MASTER. DAMAGE SHALL BE REPAIRED BY STANDARD MAINTENANCE PROCEDURES AS SOON AS PRACTICABLE.

Section I. DAMAGE CONTROL INTRODUCTION

1-1. **PURPOSE.** This Shipboard Damage Control (SDC) manual covers the assessment and repair of equipment failures occurring under emergency conditions (e.g., battle damage, fire, etc.). This repair is sometimes limited to such means of fixing as bypassing, patching, or jury-rigging components, or the use of alternative procedures to restore the equipment/system performance to a minimum operating condition. Operating procedures should be restricted to testing a system, subsystem, or component for the purpose of damage assessment, or for the purpose of testing a component or assembly after a repair has been performed. If any change to normal operating procedures is made, the new procedures must be provided to the operator.

1-2. **SCOPE.** Damage control includes the functional combination of all equipment, material, devices, and techniques designed to prevent, minimize, or restore wartime or peacetime damage. This includes passive defense for conventional, nuclear, biological, and chemical warfare, and all active defensive measures short of those designed to prevent successful delivery of enemy attack by military means or sabotage.

1-3. **IMPROVEMENT.** You can help improve this manual. If you find any mistakes, or if you know of a way to improve the procedures, please let us know. Mail your DA Form 2028 (Recommended Changes to Publications and Blank Forms), or DA Form 2028-2 located in the back of this manual directly to:

Commander, U. S. Army Troop Support Command
ATTN: AMSTR-MCTS
4300 Goodfellow Blvd.
St. Louis, Mo. 63120-1798

Section II. OBJECTIVES

- 1-4. OBJECTIVES - BASIC. The three basic objectives of shipboard damage control are:
- a. Take all practicable preliminary measures to prevent damage.
 - b. Minimize and localize such damage as does occur.
 - c. Accomplish, as quickly as possible, emergency damage repairs, restoration of equipment, and the care of injured personnel.
- 1-5. ATTAINMENT. These objectives are attained by:
- a. Preserving stability and fumetight/watertight integrity.
 - b. Maintaining the operational capability of vital systems.
 - c. Preventing, isolating, combating, extinguishing, and removing the effects of fire and explosion.
 - d. Detecting, confining, and removing the effects of nuclear, biological, or chemical contamination.
 - e. Preventing personnel casualties and facilitating care of the injured.
 - f. Making rapid repairs to structure and equipment.

The damage control organization has the same objectives in peace and war, although the threat is accentuated in war. The ship's ability to perform its assigned mission will depend upon the effectiveness of damage control.

Section III. PRINCIPAL CHARACTERISTICS

1-6. SUMMARY. The following is a brief summary of the LCU's principal characteristics:

Length (Overall)	174.0 feet
Beam (Maximum)	42.0 feet
Depth (Amidships)	11 feet, 6 inches
Maximum Draft (Full Load Displacement)	Fwd 7 feet 10 inches Aft 9 feet 3 inches Mean 8 feet 6-1/2 inches
Fuel Capacity	91,138 Gallons
Fresh Water Storage Capacity	4,642 Gallons
Maximum Continuous Speed	12.0 Knots (Approx.)

(Characteristics, CONT.)

Cruising Speed (Normal Load)	10.0 Knots (Approx.)
Range-Full Load at Cruising Speed Fuel Reserve	4,500 Nautical Miles with 50%
Main Engines	Two Cummins KTA 50-M 1250 BHP @ 1800 rpm
Generators	Two Cummins NT-855-CG2 250 kW @ 1800 rpm
Emergency Generator Diesel	Cummins 4 BT 5.9GC 40 kW @ 1800 rpm
Bow Thruster	Cummins NT-855-M 300 BHP @ 1800 rpm

Special Features:

Bow Ramp	Enables off-loading of cargo to remote, undeveloped beaches.
----------	---

CHAPTER 2
EFFECTS OF DAMAGE

SDC FIXES SHALL BE USED ONLY IN COMBAT OR OTHER EMERGENCY CONDITIONS AT THE DISCRETION OF THE VESSEL MASTER. DAMAGE SHALL BE REPAIRED BY STANDARD MAINTENANCE PROCEDURES AS SOON AS PRACTICABLE.

Section I. TYPES OF DAMAGE

2-1. GENERAL. Knowing the type of damage and what emergency repair action to take can save the ship and its crew to permit it to continue on the assigned mission or give it the capability to return to a base for more extensive repairs. Generally, most damage can be classified as follows:

- a. Large holes below the waterline.
- b. Small holes and cracks below the waterline.
- c. Holes in the hull above the waterline.
- d. Punctured, weakened, or distorted bulkheads.
- e. Flooded machinery compartments or other vital spaces.
- f. Warped or sprung doors and hatches.
- g. Weakened or ruptured beams, supports, and other strength members.
- h. Ruptured or weakened decks.
- i. Wreckage interfering with system function.
- j. Ruptured or cracked pipe lines.
- k. Severed or damaged electric cables.
- l. Broken or distorted foundations under machinery.
- m. Broken or pierced machinery units.
- n. Fire with its attendant heat, smoke, and other damage.

2-2. NATURE OF DAMAGE. The nature of repairs that a ship requires depends upon the type of damage, type of vessel, and location of damage. Collisions, grounding, and storms have in many cases caused damage so severe as to threaten the survival of very large ships. Self-inflicted damage can stem from inadequate preparation or from general neglect. Other causes impairing stability are deck icing in cold weather, excessive deck load, overloading any area in general, improper removal of ballast, and free surface effect in tanks or bilges.

Section II. BELOW WATERLINE DAMAGE

2-3. BELOW WATERLINE DAMAGE - GENERAL. Underwater damage may be from battle damage or from collision damage caused by contact with another ship or by underwater obstacles, fixed or floating.

Below waterline damage to a hull resulting from collision, explosive device, or grounding might not cause a ship to immediately sink or require abandonment but the following can occur:

- a. List.
- b. Flooding with sea water and/or fuel oil.
- c. Impairment of vital operating systems in damaged area.
- d. Fire.

The list of the ship can be presumed to be due to off-center weight. If the ship is underway when damaged and the probability of receiving further underwater damage is possible, prompt removal of list is the prime consideration. List has many undesirable effects:

- a. Impaired speed due to increased propulsion resistance, increased difficulty in operating the main propulsion plant, and possible improper immersion of screws.
- b. Impaired maneuverability.
- c. Impaired overall stability due to list and improper trim.
- d. Increased difficulty in servicing and operating deck equipment.
- e. Ultimate swamping or sinking.

A combat hit which strikes the ship's side below the waterline can cause all the effects outlined above and, in addition, may seriously decrease hull strength. A hit near the stern may damage or carry away one or both propellers and can render inoperative or destroy the rudders and steering gear.

Damage causing total flooding of tanks or void spaces below the water-line, although reducing the reserve buoyancy, may have a beneficial effect on stability if there is no list and sufficient freeboard exists. The amount of such flooding that the ship can withstand depends upon the ballast and cargo distribution before the damage occurs. New ballasting figures must be calculated using the methods described in the Trim and Stability Booklet to ensure that a safe amount of reserve buoyancy remains.

If an underwater weapon (mine or torpedo) is fuzed to explode on contact with the ship's hull, a hole is torn in the shell and the interior of the ship is subjected to blast and fragment attack, followed by a violent inrush of water. Surrounded by a liquid medium, underwater weapons do not depend upon their casing for fragment attack, but instead, tear loose large chunks of the ship's structure and hurl them into the ship with projectile-like violence.

Wiring circuits may be severed by blasts and fragments. Severed and grounded cables will interrupt power in the immediate vicinity and can short the entire electrical system. If the damaged area is aft, machinery spaces can be flooded. The power plant can be affected; possibly all propulsion will be lost.

Underwater damage depends mainly on the weight of the bursting charge. Because of the large amounts of explosive used in modern mines and torpedoes, the holes opened in the shell of the ship by these weapons will be very large.

Flame from incandescent gases created by explosion, unless dampened by liquids, can spread through the affected area. Hot fragments can also start fires in remote areas. Acrid smoke and toxic gases from explosion and fire will necessitate the use of oxygen breathing apparatus.

When a vessel sustains underwater damage, violent shock may break or derange delicate radio, radar or navigation equipment. Brittle materials such as valve bodies or cast-iron base plates under machinery can be fractured even at considerable distances from the damaged area. Shock frequently opens circuit breakers. Violent heaving of decks can cause personnel injury, particularly to those who are standing at the time of impact.

2-4. WATERTIGHT SPACES. Watertight integrity below the main deck of the LCU is provided by the installation, during construction, of athwartships bulk- heads at frames 5, 17, 25, and 44.

At or above the main deck, compartments are protected by watertight doors as follows:

At the main deck level, watertight doors forward protect the damage control locker, the bosuns storeroom, and the paint locker.

Port side main deck watertight doors lead to the galley, and the dry provisions storeroom.

Starboard side main deck watertight doors lead to the passageway, and the air conditioning and the emergency generator room.

Section III. FIRE

2-5. FIRE DAMAGE. In addition to the structural damage caused by battle or collision, fire is almost certain to follow. Unless the fire is extinguished speedily and effectively, more serious damage than that caused by the initial problem can result. Many ships have been lost by fire. Experience indicates that steel ships can become floating furnaces, fed by the combustible and flammable materials carried on board. Some ships have become blazing infernos which had to be abandoned and later sunk by our own forces because fires got out of control and prevented the effective application of damage control actions.

Fire may cause the loss of a ship after other damage has been repaired or minimized. There is a substantial amount of combustible material on board the LCU. Fire must be considered a potential hazard requiring every effort to eliminate, control, and extinguish.

Section IV. CORRECTIVE MEASURES FOR CONTROL OF DAMAGE

2-6. INTRODUCTION. This section is designed to cover the basic equipment, procedures, and techniques for preventing or minimizing ship damage resulting from fire, explosion, grounding, collision, flooding, or adverse weather.

a. Keep the bridge informed. A prime consideration in damage control is keeping the bridge informed. The timeliness and accuracy of all reports to the bridge will have a direct bearing upon the speed and success attained in correcting the damage. The bridge must be continually informed of progress in correcting damage, and particularly of a deteriorating situation. A continual flow of information to the bridge must be maintained by the most efficient and rapid means available. Excess reporting is better than too little.

b. Initial report. Reporting known or suspected damage is an all-hands responsibility. The speed with which the bridge is informed of damage and the accuracy and thoroughness of the report will be key factors in reducing material casualties. Anyone aware of damage (fire, smoke, explosion, flooding, etc.) shall immediately report the incident to the bridge (quarterdeck in port) by the fastest means possible stating:

- (1) Type of damage (if known).
- (2) Location (compartment noun name, frame, deck, port/starboard side, etc.).
- (3) Estimate of extent of damage (if known).
- (4) Name and grade/rate, and telephone number (if used) of individual reporting damage.

There will be many cases which should be corrected "on the spot" by the individual discovering the damage. All damage, including that seemingly minor and corrected by the crew member alone or with the help of one or two others, shall be reported to the Vessel Master.

c. Battle dress. When general quarters is sounded, battle dress will be promptly donned. Long-sleeved shirts, safety shoes, helmets, and life jackets will be worn. Protective masks will be broken out and ready for use. Relaxing of full battle dress may be authorized by the Vessel Master in spaces where it restricts necessary personnel movement (for example, on the bridge, and in main engineering spaces). In these cases, those items will be available in a location known to personnel involved. Personal clothing will be adjusted to cover maximum body area to prevent flash burns.

2-7. CONTROL PROCEDURES.

a. Investigating and reporting damage. It is presupposed that the damage has been initially reported to the bridge and the damage control organization has responded. Therefore, actions described herein are those which should be carried out by the damage control organization and reported to the bridge.

When the damage is reported or suspected as a result of any outside influence, an immediate investigation shall be conducted to determine the type and extent of damage. Prompt investigation and accurate reporting will allow the engi

neer to evaluate the damage, to make effective repairs, and to keep the bridge informed of the extent of damage, the corrective action in progress or recommended, and the status of ship's stability and maneuverability.

While the need for immediate investigation of damage is stressed, the need for caution on the part of the investigators remains paramount.

WARNING

Investigators will wear oxygen breathing equipment when entering the damaged area, work in pairs, and maintain communications with assistants outside the damaged area. When the situation permits, no closed space or void will be entered until the area has been cleared by the Chief Engineer. Should fire, flooding, or other factors prevent first clearing the area by the Chief Engineer, investigators will continue, but assume that hazardous conditions exist such as the presence of flammable/explosive or toxic fumes and that the space does not contain adequate oxygen to sustain life. Serious personal injury is possible.

b. Preliminary investigation of damage. The degree of investigation required immediately after a ship has suffered damage depends upon the location and the extent and type of damage. Certain information as to the extent of damage will be available almost immediately.

Heavy shock and whipping of the hull structure may indicate a major underwater explosion, although intense vibration will not always occur on large ships. A decided or progressive change in trim or list indicated by clinometers will also provide information. Additional information will come from the damage control team near the scene of the damage. For example, the bridge may report that steering control has been lost, and engineering may report that water is coming through a certain bulkhead.

The foregoing information is preliminary, but combined with reports from look-outs and other topside personnel, or from below-decks personnel, it will locate the damage and give a general picture of its extent. On the other hand, there may be a few obvious signs of damage: a minor loss of power, smoke, a dropping pressure gauge, unusual temperature change within a space or on a bulkhead, or a slight seeping of liquid at a seam. All of these indications should be investigated thoroughly. They are symptoms of a dangerous condition, and prompt remedial action must be taken if the ship is to survive.

c. Four basic principles of investigation:

- (1) Investigation should be thorough.
- (2) Investigation should be conducted with caution.
- (3) Reports should be accurate.
- (4) Investigations should be repeated to guard against overlooking subsequent or progressive damage.

Ships have been lost or have suffered unnecessary fires or flooding damage merely because investigating crew members have neglected one, or more of the above principles.

d. Compartments adjacent to damaged area. Major damage is often more extensive than preliminary examination might indicate. Investigation should cover all spaces, systems, and structures in every compartment adjacent to the damaged area, even to a depth of two or three compartments in all directions. This is to locate any additional damage and to establish gas, flooding and fire boundaries around the damaged areas.

e. Inspection of entire ship. If an underwater explosion occurs close to the side of the ship, all voids, tanks, and lower compartments shall be investigated. All fuel oil tanks on the ship should be investigated for damage by taking samples of the oil and testing them for water. Likewise, potable and feed water tanks should be tested for salinity. There shall be a sounding detail in each repair party, and all crew members should know where and how to sound oil compartments in their own and adjacent areas.

f. Safety measures.

WARNING

Investigation of structural damage by visual examination presents many difficulties and dangers. To do a thorough job, it will often be necessary to open one or more watertight doors or hatches. It is unwise to open any such closures in the vicinity of damage, and it should be done only after a thorough investigation by means of soundings, and after obtaining permission from Vessel Master or Chief Engineer whenever the situation permits. Opening a door or hatch to a flooded space will result in additional flooding.

No watertight door, hatch, scuttle, or manhole should be opened until it is known definitely that the compartment on the other side is either completely dry or that flooding is minimal enough that opening the closure will not permit flooding to spread. When a compartment is equipped with a sounding tube, the existence of flooding can be determined by slowly loosening the sounding tube cap. If air escapes under pressure followed by a trickle of water, a solidly flooded compartment is indicated, while the escape of air only indicates a partially flooded compartment. Many compartments are not provided with the air escapes; however, this is no bar to investigation. Tapping on a bulkhead with a hammer or backing off on the air test cap will often disclose the presence of water on the other side; the exact height of water may be judged by variation in the tones produced when the bulkhead is struck at different levels.

Inaccuracies caused by a hidden frame may be avoided by tapping the bulkhead at two locations.

A dangerous but often necessary method of testing a compartment for flooding is to back off slowly on some of the dogs which hold a hatch or a door closed. Crew members have made the irretrievable error of first loosening the dogs on the edge of the door away from the hinges. This results in the door buckling or flying open and another compartment needlessly flooding. The correct procedure is to slack off slightly on the dogs adjacent to the hinges where there is a slight amount of clearance around the hinge pins. As the dogs are loosened, water, if present, will begin to trickle between the gasket and the knife edges on that side. Control is still maintained by the hinges and the opposite dogs. This method cannot be used with quick-acting doors or scuttles where the hatch dogging devices are interconnected.

CAUTION

Investigators should take no action which might cause loss of control of a watertight fitting, and all compartments must be resecured after leaving them. Failure to do so creates a hazard to the survival of the ship.

As in the case of progressive flooding through damaged or improperly maintained fittings, fire, gas and smoke may be spread in a similar manner. Open flues such as trunks and ventilation ducts are potential sources of trouble. The latter are especially dangerous, for if they contain flammable dust or are not properly secured, they will carry fire to other parts of the ship. Fire has been known to travel along electrical cables, and the heat transferred by metal bulkheads has caused fires in parts of the ship far distant from the original source. It is necessary to inspect a wide area around the scene of a fire in order that the damage may be localized. The danger of overheating magazines and ammunition stowage areas must be avoided. Care should also be exercised when opening watertight hatches or scuttles into the compartments suspected of containing fire. There is a distinct possibility that heat within the compartment may build an overpressure within the space, below the hatch, and belch fire and smoke when the dogs are loosened.

g. Initial steps of control. After the initial investigation, steps shall be taken to localize and control the damage, and investigate for hidden potential damage. Repair party provided with protective equipment, lighting and ventilating facilities, and other required tools shall take the following general steps:

WARNING

Crew members must wear an Oxygen Breathing Apparatus (OBA) while fighting fires below decks and should wear this equipment whenever possible while fighting fires on weather decks or similar open areas. Failure to do so can cause serious personal injury.

(1) If fire is present, the firefighting party must begin operations immediately.

(2) Electrical circuits in the damaged area should be secured, preferably by removing fuses in a compartment at a distance from the scene of damage.

(3) Pipelines in the damaged area may be ruptured and valves may be destroyed. If the lines are so badly damaged that they cannot be repaired at once by soft patches or similar methods, the damaged sections must be isolated at the first intact stop outside the damaged area.

(4) The air in a damaged area may be fouled with smoke, fumes, and gases. Furthermore, a compartment may be so hot that the repair party cannot remain in it. It may be necessary to provide fresh air through the regular air-conditioning system (provided no fire is present), by means of portable blowers, or by bleeding from the ship's service air lines. Hot compartments can be cooled by spraying them with water, using fog nozzles.

(5) If there is no fire in the compartment and it is necessary to employ spark-producing equipment in the area to make repairs, fire extinguishers will be brought to the scene and the air will be tested for toxic or explosive gases and for lack of oxygen before repair work is commenced.

h. Damage control recovery procedures. When the initial steps of control are completed and when the situation permits, follow-on steps will be initiated to restore the ship to the maximum possible combat readiness condition.

2-8. FIREFIGHTING - See Chapter 6, Fire.

CHAPTER 3

VENTILATION

SDC FIXES SHALL BE USED ONLY IN COMBAT OR OTHER EMERGENCY CONDITIONS AT THE DISCRETION OF THE VESSEL MASTER. DAMAGE SHALL BE REPAIRED BY STANDARD MAINTENANCE PROCEDURES AS SOON AS PRACTICABLE.

Section I. INTRODUCTION

3-1. GENERAL. Ventilation systems are a potential means of flooding and also contribute to the spread of fire and dangerous fumes. The duct work openings (supply and exhaust), penetrations of bulkheads and decks, associated fans (supply and exhaust), and numerous other components offer many opportunities for progressive flooding and spread of fire, smoke, and toxic fumes when the ship is in a damaged condition.

Section II. VENTILATION OF HALON-FITTED SPACES

3-2. LCU HALON SPACES. The Engine Room and Paint Locker are fitted with HALON fire extinguishing systems. When HALON is released in the space, the ventilation system and closures serving these spaces should be secured immediately to prevent dilution of the HALON as well as its removal from the space.

The supply system and exhaust system are provided with interlocking switches which shut down the ventilation fans when HALON is released into these spaces. This is accomplished automatically by pressure-operated switches which cut out the ventilation fan motors when HALON is released in this space, thereby preventing the excessive dilution of the HALON as well as its removal from the space. The emission of HALON also actuates a visual yellow light and a pressure-operated siren.

Section III. SETTING OF CLOSURES

3-3. WATERTIGHT CLOSURES. Ventilation ducts which pierce watertight bulkheads or decks below the tightness level are fitted with watertight closures at the penetrations, or, as in most cases where ducts pierce decks, the ducts are constructed watertight up to the tightness level. Penetrations of the main transverse bulkheads below the second deck are not permitted.

In the event that a Nuclear, Biological, or Chemical (NBC) attack is imminent, all ventilation fans and blowers must be secured in order to prevent contaminants from entering the ship. Ventilation should not be restored until the ship is clear of the contaminated area and the ship has been decontaminated.

CHAPTER 4

DAMAGE CONTROL EQUIPMENT

SDC FIXES SHALL BE USED ONLY IN COMBAT OR OTHER EMERGENCY CONDITIONS AT THE DISCRETION OF THE VESSEL MASTER. DAMAGE SHALL BE REPAIRED BY STANDARD MAINTENANCE PROCEDURES AS SOON AS PRACTICABLE.

Section I. INTRODUCTION

4-1. INTRODUCTION. The LCU's damage control equipment is used to reduce the seriousness and extent of an emergency, protect the crew, and effect temporary repairs. Damage control equipment is not to be used for routine maintenance or repair activities. Any piece of damage control equipment used in combating an emergency must later be restored to its original operating condition and location. The safety of the vessel and the personnel on board are dependent upon the specified equipment being properly stowed and ready for use at all times. It is important that all crew members be familiar with the location and use of the various pieces of damage control equipment.

Section II. DAMAGE CONTROL EQUIPMENT - GENERAL DESCRIPTION

4-2. EQUIPMENT - GENERAL. Damage control equipment on the LCU consists of firefighting gear, extinguishers, fire stations, fire axes, the Halon fire system, fireman outfits, oxygen breathing apparatus, life jackets, life rafts, life rings, and shoring.

Section III. DAMAGE CONTROL EQUIPMENT ON THE LCU

4-3. EQUIPMENT - LCU. Damage control equipment/tools are located in the two damage control equipment lockers; (1) main deck, forward, next to boatswains storeroom and (2) main deck, after starboard side, 01 level.

<u>Description</u>	<u>Quantity</u>
Alarm, Gas Oxygen with Probe	1
Bar, Wrecking, 30"	1
Bar, Wrecking, 36"	1
Battle Lantern (Handle and Switch)	5
Canister, OBA	4
Carbon Monoxide Colormetric Detector Kit	1
Damage Control Shoring Kit	1
Detector Kit, Chemical Agent	1

<u>Description</u>	<u>Quantity</u>
Eductor, Bilge, 4"	1
Fire Suit	2
Gloves, Asbestos	2 ea.
Hammer, Sledge, 10 lb.	1
Hatchet, Half	1
Lamp, Flame, Safety	1
Maul, 5 lbs.	1
Oxygen and Acetylene Cutting Torch Outfit	1
Oxygen Breathing Apparatus (OBA)	2
Paper, Chemical Agent Determination	6 boxes
Pump, Electric Submersible	1
Pump, Portable Fire and Salvage Centrifugal	1
Saw, Hand, 26" long	1
Tool Kit, Electrician	1

Section IV. LIFE JACKETS

4-4. LIFE JACKET LOCATION. Life jackets are installed as follows:

- 2 Pilothouse, 02 Level
- 2 Officers Staterooms (1 each), 01 Level
- 11 Crew's Stateroom, 01 Level
- 1 Machinery Control Room
- 1 Boatswain Storeroom

4-5. EXPOSURE SUIT (WITH WHISTLE) LOCATIONS. Exposure suits are installed as follows:

- 2 Pilothouse, 02 Level
- 2 Officers Staterooms (2 each), 01 Level
- 11 Crew's Stateroom, 01 Level

- 1 Machinery Control Room
- 1 Boatswain Storeroom

4-6. NUCLEAR, BIOLOGICAL, AND CHEMICAL EQUIPMENT. NBC equipment and clothing is stored in the Arms Control Room and includes protective masks and Mission Oriented Protective Posture (MOPP) suits.

Section V. SOUND-POWERED TELEPHONES

4-7. TELEPHONES - GENERAL. Telephones provide a rapid means of transmitting and receiving verbal orders and information among various stations in the ship.

Sound-powered telephones are powered by the energy of the speaker's voice and provide functional shipboard communications. As its source of power, the equipment uses the audio energy in the sound waves of the speaker's voice. Audio energy is converted to electrical energy by the transmitter (microphone).

An alternating current produced by audio energy is impressed on the coil of the receiver unit and causes the diaphragm of the receiver to vibrate in unison with the transmitter diaphragm. In this way, the receiver generates sound waves which correspond to those impressed on the transmitter by the talker's voice, and the speech is reproduced at the receiver.

4-8. SOUND-POWERED HANDSET. The handset transmitter receiver is used primarily for one-to-one talking. The transmitter and receiver units are interchangeable. The handset is provided with a normally open, nonlocking spring return switch in the handle. When depressed, the press-to-talk switch configuration connects both the transmitter and receiver in parallel across the line. When the switch button is released, both transmitter and receiver are disconnected.

4-9. SOUND-POWERED HEADSET. The headset-chestset type transmitter-receiver is designed for general use. The transmitter and receiver units are not interchangeable. The set has two receiver units in protective shells with ear cushions. Closing the press-to-talk switch connects the transmitter across the line. The receiver units are connected across the line at all times when the headset-chestset is plugged in.

4-10. HANDLING AND STORING SOUND-POWERED TELEPHONES. The procedure used to prepare a headset for storage is:

- a. Hold plug and unscrew from jack box; remove by pulling on the plug, not on the cord.
- b. Screw cover on the jack box to keep out moisture and dirt.
- c. Remove headband and hang the headband over the yoke of transmitter.
- d. Lay line out on the deck and remove any kinks; begin coiling from the end that attaches to the chest plate. Coil line with right hand, making the loops in a clockwise direction; loops should be about 10 inches across.

- e. When lead is coiled, remove ear pieces from transmitter yoke and hold headband in the same hand with the coil.
- f. Fold transmitter yoke flat so transmitter mouthpiece lies flush against the breast plate connection box, using care not to pinch transmitter cord.
- g. Holding headband and coil in the left hand, unhook one end of neck strap from chest plate.
- h. Bring top of chest plate level with coil and headband. Secure chest plate in this position by winding neck strap around coil and headband just enough times so there will be a short end left over. Twist this end once and refasten it to chest plate. The headset is then made up in a neat package ready for stowage.

CAUTION

A set properly made up fits into its stowage box without forcing. Never allow loose cord to hang out of the box because it may be damaged when the lid is closed. Stow only battle telephones in telephone storage boxes; never put cleaning gear or tools in these boxes. Failure to do so can seriously damage the equipment.

Sound-powered handsets are fastened to a connection box by a coiled cord. A stowage hook or handset holder is provided for each handset, and the set must be properly replaced in the holder at all times when not actually in use. FIGURE 4-1 shows a typical made-up headset.

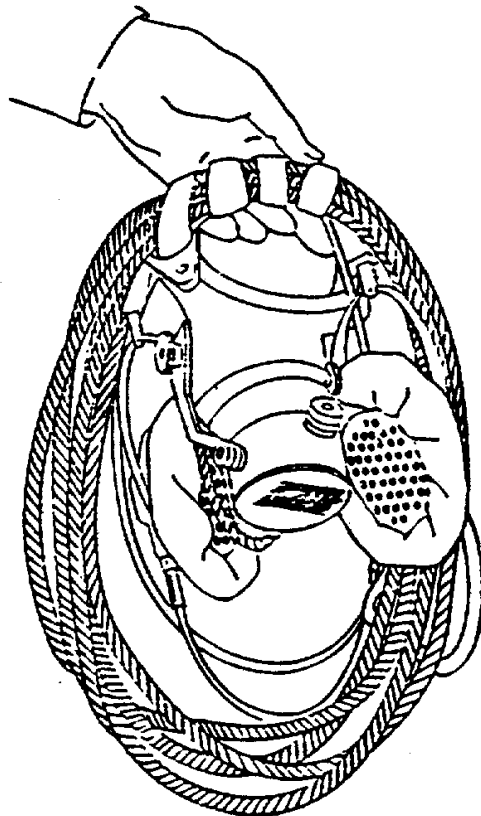

PED/SDC-1

FIGURE 4-1. A Typical Made-Up Headset.

4-11. LCU SOUND-POWERED PHONE SYSTEM. The LCU is provided with three different sound powered circuits to ensure good, reliable communication during ship operations and special evolutions.

a. Circuit IJV. The 1JV is primarily used during restricted maneuvering to communicate changes of engine speed, steering orders in the event of a steering casualty, checking gyro and standard compasses, and orders to line handling and under way replenishment stations.

In addition, the 1JV provides the Engineer a means to communicate orders to the damage control teams. Consequently, the repair parties report damage flooding, fires, status of watertight integrity and personnel casualties.

Communication is provided between the following locations:

<u>Station Numbers</u>	<u>Locations</u>
1	Propulsion Control Console
2	D.C. Central
3	Engineer's Stateroom
4	Master's Stateroom
5	Galley
6	Emergency Generator Room
7	D.C. Locker (aft)
8	Steering Gear Room
9	Engine Room Control Room
10	Bowthruster Room
11	Boatswain Storeroom
12	D.C. Locker (fwd)

b. Circuit 2JV. The 2JV circuit provides a means of communication between the control room and propulsion plant for the operation of each main propulsion diesel engine.

Communication is provided between the following stations:

<u>Station Numbers</u>	<u>Locations</u>
1	Engineering Control Room
2	Main Propulsion Diesel Engine (Port)
3	Main Propulsion Diesel Engine (Starboard)

c. Circuit JA. The JA circuit is used by the Captain to coordinate various battle stations and beaching operations.

Communication is provided between the following stations:

<u>Station Numbers</u>	<u>Locations</u>
1	Pilothouse
2	.50 Caliber Machine Gun, Starboard
3	.50 Caliber Machine Gun, Port
4	Bow Ramp
5	Stern Anchor

Section VI. LS-519A/SIC INTERCOMMUNICATION SYSTEM

4-12. INTRODUCTION. The LS-519A/SIC Intercommunication system has a capacity for 20 stations. Ten stations are presently being used which allow 10 stations for future expansion. The 10 stations in use are at the following locations:

- Pilothouse
- Master Stateroom
- Chief Engineer Stations
- Galley
- Recreation Room
- Sick Bay
- Bowthruster Compartment
- Machine Shop
- Engineer Operating Station
- Steering Gear Compartment

Each unit contains all necessary equipment to provide two-way voice communication between any two stations simultaneously. The system is powered by 115 Vac, 60 Hz, single phase power.

The controls on each LS-519A/SIC master station consist of:

- a. Two 10-pushbutton station selector switch assemblies which are used to call the desired station.
- b. A microphone or headset connector if either is to be used.
- c. A HANDSFREE/NORMAL/PRESS-TO-TALK switch. The HANDSFREE position allows the operator to talk and listen without pushing the switch to the PRESS-TO-TALK position.
- d. A VOLUME control switch for incoming loudspeaker audio.
- e. A DIMMER switch for illumination control.
- f. A release (REL) lamp, CALL lamp, and a BUSY lamp.

There are also several remote loudspeaker (talk back) stations. These stations consist of loudspeakers, talk switches, and busy indicators. Each remote talk back speaker is connected to only one master station and not to the entire intercom network. If a communication is initiated from the master station, the remote operator replies handsfree. If the communication is initiated from the remote loudspeaker station, the remote talk switch must be maintained in the talk position to receive the reply from the master station, unless the master station operator operates the selector switch for the calling station.

Section VII. GENERAL ALARM SYSTEM

4-13. GENERAL. In the event of an emergency, the general alarm may be activated from either the pilothouse or the emergency generator room in order to alert the crew. The general alarm system consists of 14 bells throughout the ship and a high intensity red strobe light in the engine room. The 8-inch bells are located in the following spaces:

- 01 Level, Centerline, Frame 33
- 01 Level, Centerline, Frame 41
- Pilothouse, Centerline, Frame 34
- Boatswain Storeroom
- Paint Locker (explosion-proof)
- Emergency Generator Room
- Main Deck Passageway, Centerline, Frame 33
- Bowthruster Compartment
- Tunnel, Frame 17
- Tunnel, Frame 25
- Engineering Room, Port, Frame 28
- Engineering Room, Starboard, Frame 28
- Engineering Room, Centerline, Frame 32
- Steering Gear Compartment

CHAPTER 5

STABILITY AND BUOYANCY

SDC FIXES SHALL BE USED ONLY IN COMBAT OR OTHER EMERGENCY CONDITIONS AT THE DISCRETION OF THE VESSEL MASTER. DAMAGE SHALL BE REPAIRED BY STANDARD MAINTENANCE PROCEDURES AS SOON AS PRACTICABLE.

Section I. INTRODUCTION

5-1. PURPOSE. The purposes of this chapter are to explain the stability characteristics of the Landing Craft Utility (LCU) insuring the ship will be seaworthy in the intact condition and to discuss the capability of the ship to survive the greatest practical amount of underwater damage. In this regard, the LCU is a single compartment ship, meaning that a satisfactory condition of reserve buoyancy exists after flooding of any one compartment.

Section II. DEFINITIONS

5-2. METACENTER. In this discussion, the term "initial stability" refers to the tendency of the ship to right itself when inclined to small angles of heel, under 7 degrees, for example.

To facilitate the determination of initial stability, the concept of metacenter is introduced. With the ship at a given draft, the metacenter is the point of intersection of two successive lines of action of the force of buoyancy as the ship is inclined through a very small angle. In FIGURE 5-1, point M designates the initial metacenter, that is, the intersection of the buoyant force at 0 degrees with the line of action of buoyancy at a small angle (Θ) away from 0 degrees. The distance GM between the center of gravity (G) and the metacenter (M) is called the metacentric height.

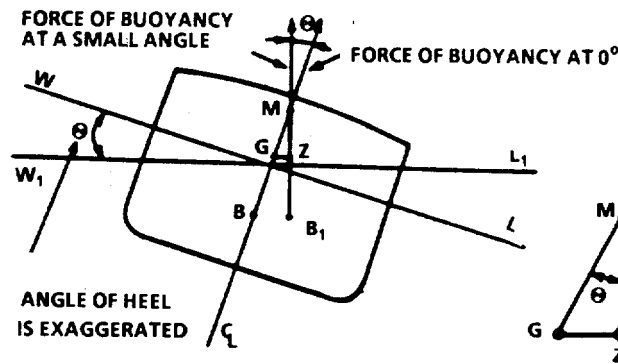

PED/SDC-2

FIGURE 5-1. Initial Metacenter with Line of Action Buoyancy Angled Away From 0° .

5-3. **RIGHTING ARM.** When the ship is upright, the water line is WL and the forces will act as shown in FIGURE 5-1. When the ship is inclined, however, the water line becomes W_1L_1 , which changes the shape of the underwater body. As a result, the center of buoyancy moves from B to a new position B_1 , and the weight and buoyancy no longer act in the same vertical line. Examination of the figure will show that a righting arm or restoring moment is now present, which tends to rotate the ship toward its original position. The distance GZ is the righting arm.

a. The ship in FIGURE 5-2 develops positive righting arms from $-\theta$ to C , that is, from 0 degrees to 71 degrees. This series of angles through which the ship has positive righting arm is called the range of stability. It indicates the extreme angle to which the ship can roll.

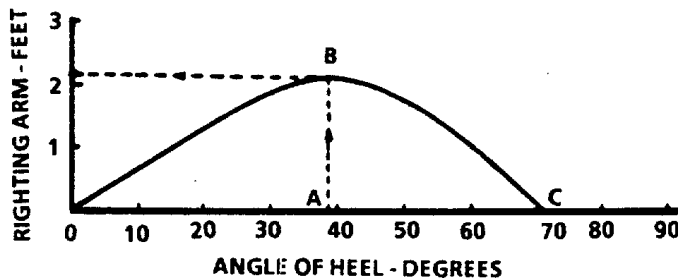

PED/SDC-3

FIGURE 5-2. Stability Curve Indicating Maximum GZ .

b. Thus, if the ship in the example is in a seaway and rolls to, 70 degrees, for example, it will come back to the upright. But if the extreme angle of a roll exceeds 71 degrees, the ship will capsize, because upsetting moments develop beyond this angle.

5-4. METACENTRIC HEIGHT. The distance GM between the center of gravity and the metacenter is called the metacentric height.

a. This distance is a measure of how much B moves when the ship inclines through an angle of heel, Θ . In the triangle GZM, FIGURE 5-1, the righting arm GZ will always be proportional to GM. This holds true as long as M remains on the ship's centerline; i.e., from 0° to about 7°. Therefore, GM is a measure of initial stability for any given displacement, W. Unless otherwise specified, further reference to metacentric height will refer to initial GM.

b. The point M does not come into being until the ship heels, but any slight inclination produces a movement of B and consequently a metacenter is established. Note that the GM produced by a slight heel in an upright position is a definite value which remains relatively constant up to about 7° of heel.

c. Since at small angles of heel large values of GM indicate large righting arms, ships with large GM are stiff and resist roll. Small values of GM reflect slowly developed righting arms, and these ships are tender and roll slowly. Ships with very small GM are apt to hang at the extreme angle of a roll before starting back.

d. A study of FIGURE 5-3 will indicate that when G is below M, GM is positive and righting arms develop, whereas when G is above M, GM is negative and upsetting arms develop. Thus, GM is an indicator of whether initial stability is positive or negative.

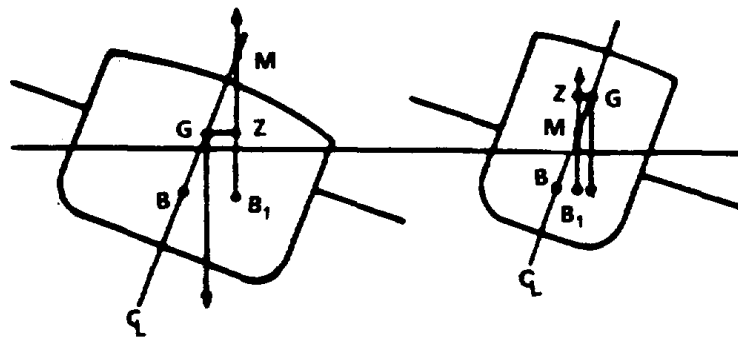

PED/SDC- 4

FIGURE 5-3. GM Indicating Initial Stability. Positive/Negative.

e. Therefore, timing the roll is of little practical use in evaluating damaged stability. Knowledge of this relation between period of roll and GM is useful in giving one the general feel of the ship's stability as it rolls. A ship which has a long roll has low GM; a stiff ship has high GM.

5-5. ANGLE OF LIST AT WHICH MAXIMUM RIGHTING ARM (GZ) OCCURS. General information regarding angle at which maximum righting arm develops:

a. In FIGURE 5-2, the maximum value of the righting arm occurs at A, an angle of heel of about 39°.

b. The angle at which the maximum righting arm develops is significant because it is the angle of inclination beyond which the ship cannot safely assume a permanent list, even under ideal conditions in calm water.

5-6. DYNAMIC STABILITY. The work that must be done on a ship to heel it over is equal to the moment with which the ship resists inclination (righting moment) times the angle through which this moment acts. Hence, dynamic stability is equal to righting moments times angles of inclination. If the cause of the inclination is removed, the dynamic stability becomes available as energy to return the ship to its upright position.

In a sense, this is similar to the work done in compressing a spring. When the pressure is removed, the spring can do work as it expands, delivering back the energy used to compress it.

On the ship's curve of righting moments (FIGURE 5-4), the area between the curve and the base represents the product of the moments (measured vertically) times the angles (measured horizontally) through which the ship heels. Therefore, the area under the curve up to a given angle represents the dynamic stability of the ship at that angle. That amount of work must be done on the ship to heel it, and that amount of energy will become available to right the ship when the cause of the inclination is removed.

In FIGURE 5-4, the dynamic stability at 25° is represented by the shaded area. The unshaded area under the curve is the reserve of dynamic stability; i.e., the work that must be done beyond 25° to continue heeling the ship until it capsizes.

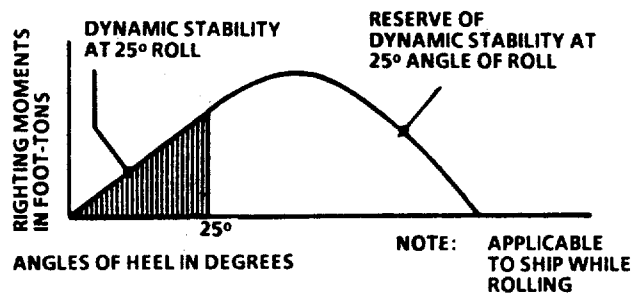

PED/SDC-5

FIGURE 5-4. Ship's Curve Of Righting Moments, Example.

Section III. STABILITY CHARACTERISTICS

5-7. CHARACTERISTICS

- a. Initial stability. This term refers to the tendency of the ship to right itself when heeled or inclined to a small angle, under 7°, for example. Initial stability is measured by metacentric height (GM) which is explained in paragraph 5-4.
- b. Range of stability. This term refers to the angles of heel through which the ship maintains a positive righting arm. See paragraph 5-3 for explanation of the righting arm.
- c. Maximum righting arm. This characteristic can be an indicator to the ship's personnel of a hazardous condition in heavy seas. If the ship rolls beyond the angle of the maximum right arm, it is prudent to change course to lessen the roll. Also refer back to paragraph 5-3.
- d. Angle of list at which maximum righting arm occurs. See paragraph 5-5.
- e. Dynamic stability. This characteristic is explained in paragraph 5-6.

Section IV. DAMAGE RESISTANCE CHARACTERISTICS OF THE LCU

5-8. DAMAGE RESISTANCE FEATURES. The damage resistance features of this ship are:

- a. Strength.
- b. Watertight integrity.
- c. Stability.
- d. Proper displacement.
- e. Proper distribution of liquids.
- f. Optimum material and personnel readiness.

The maintenance of these features before accidental or battle damage is as important for ultimate survival as damage control measures after the damage is sustained.

In spite of the inherent resistance of ships and in spite of all precautions that can be made before damage, the survival of the ship will often depend upon prompt and correct control measures after damage. It is necessary, therefore, to train the entire ship's crew for any eventuality.

a. **Strength.** In this ship, the main and hold decks and the shell, with their associated longitudinals, e.g., wingwalls, constitute the principal strength members. Together with other decks, bulkheads, and framing, the main deck and the shell carry the stress imposed on the ship by its weight and the action of the sea. These structural members resist damage and possess a sufficient margin of safety to permit the ship girder to withstand considerable structural damage without failure.

b. **Watertight integrity.** Watertight subdivision is provided to halt the ingress of water into the ship after damage and to limit the spread of flooding. Generally, increasing the subdivision greatly enhances a ship's ability to remain afloat following damage. Whenever flooding occurs at a substantial rate, the ship's life is in jeopardy. Removal of flood water is futile until ingress is halted or slowed. Hence, watertight integrity with the proper material condition must be strictly maintained before damage to ensure that any resultant flooding will be localized; this is accomplished in the following manner:

(1) Transverse bulkheads are arranged to divide the ship into sections so that it can withstand flooding of one major compartment.

(2) In order to avoid large heeling moments, longitudinal bulkheads are limited in number to prevent off-center flooding.

(3) Rigid closure discipline of watertight doors, hatches, vent ducts, and so forth, must be maintained before and during operations, underway or beached, where the ship may be exposed to accidental or battle damage. Open doors and hatches will not reduce the effect of an explosion by venting it, but will only permit flooding, fires, and other effects of the explosion to spread.

c. **Stability.** Adequate stability characteristics are provided to make a ship seaworthy and keep it from capsizing after absorbing damage resulting in flooding of no more than one watertight subdivision. Preservation of satisfactory stability characteristics requires adherence to liquid loading instructions, remaining within the specified limiting drafts, removal of any unusual topside weights, and maintenance of a proper degree of watertight integrity.

d. **Proper displacement.** Overloading has the adverse effect of reducing freeboard and reserve buoyancy. Plimsoll marks on the sides of the ship show the limiting drafts. Limiting displacements and drafts have been established for this ship. See the Trim and Stability Booklet.

e. **Proper distribution of liquids.** The Liquid Loading Diagram (FIGURE FO-1) shows the distribution and amounts of liquids normally carried on board and the effect on trim and list of filling each tank with its normal capacity of liquid.

Section V. MEASURES TO RESIST FLOODING BEFORE DAMAGE

5-9. PURPOSE. Ninety percent of the work of damage control, the important part, is accomplished before damage, and only about 10 percent after the ship has been damaged. Much of this preparatory work consists of measures to toughen the ship to resist flooding. The purpose of this section is to discuss these measures from the standpoint of buoyancy and stability.

5-10. COMBATING FLOODING. Both speed and accuracy are required in combating flooding. To be effective in applying corrective measures, damage control personnel must be familiar with the equipment provided to control list and trim and to improve stability. Preparing damage control bills that establish procedures to be followed in the event of flooding is also recommended. These might include a drainage bill and a jettison ship bill as described in the paragraphs that follow.

5-11. DRAINAGE BILL. Since the ship's drainage facilities (including portable pumping equipment) provide means to suppress free surface and remove weight, some thought should be given to assigning a priority to the elimination of loose water and high weight before low weight and solid flooding. Damage control officers should also make themselves aware of the fact that removal of flooding water from one side of the ship is of the greatest benefit in correcting off-center weight, but this may be disastrous to the damaged ship with negative GM and symmetrical flooding.

5-12. JETTISON SHIP BILL. The jettisoning of topside weights involves time, seamanship, and a subsequent loss of mission efficiency. Consequently, the jettisoning bill should establish the following:

a. A sequence which begins with the more easily removed and less vital weights. The bill should specify the approximate gain in stability from removing each of the weights involved in order to give responsible officers some idea of the relative importance and results to be attained.

b. A plan of action and responsibility. To be effective, jettisoning must remove tons (not pounds) of weight from high levels. The consequent problem of shifting/removing topside weights, cargo, or ballast is of large magnitude, often covering many hours of back-breaking work to restore seaworthiness to a crippled ship. The speed of gaining some immediate effect will be enhanced by a plan of action which outlines responsibility for removals, organization of jettisoning teams, and preparation of tools and methods.

5-13. FLOODING EFFECT BILL. The LCU has six sea water ballast wing tanks which make it subject to off center flooding. Since these tanks will be empty in the Fully Loaded Departure Condition, off center flooding due to collision or grounding is possible. The Damage Stability Report indicates flooding of the largest sea water ballast tank (either 5P or 5S) will result in a 10° list when in the fully loaded (350 Ton) condition. Coast Guard stability criteria is still met in this condition. However, it would not be safe to counter flood to remove the list because additional weight will severely impact stability. The only practical means to alleviate the list is to put on service a fuel tank on the opposite side as the ruptured sea water tank (5S or 5P).

It is of value to calculate free surface effect (i/V) and enter these on the liquid loading diagram of the casualty board (some ships also note these on the flooding effect diagram). Ships have in some cases prepared for themselves a so-called flooding effect bill. This consists of a tabulation of all the compartment numbers in the ship with the value of free surface effect (i/V) entered opposite each.

- a. The "i" is for the moment of inertia for the compartment
- b. The "V" is used for battle displacement in tons.

Such tabulations may also indicate information on added weight effects (and free communication effect if applicable).

The foregoing calculations are of great value in predicting the possible flooding effects to be expected, provided that those who use them realize that their values are indicative, not exact, and that good judgment and common sense, based on an understanding of the principles involved, are better than any number that can be computed.

5-14. CREW INDOCTRINATION. All crew members should be educated in the general effects of a missile hit at the waterline or other underwater damage, as will be described in Measures to Safeguard Stability (Section VIII). Since a single hit may wipe out an entire repair party, ships may have to depend on other than repair parties to confine flooding and fire, and to perform other emergency functions. More important, ships have been lost because crew members escaping from damaged areas left doors and hatches open behind them, thus permitting rapid spread of water. The opposite of this should be impressed on all crew, to confine the flooding, or else stability efforts may be too little and too late.

Repair parties should be drilled to take action automatically to halt the flooding; to plug, patch, and shore to eliminate further damage; and to begin immediately the removal of flooding water, giving priority to loose water and high flooding. Repair parties also should be drilled to make prompt, accurate reports to the damage control center on the nature of the flooding and the action being taken to combat it.

5-15. MATERIAL PREPARATIONS. There are certain material preparations which are vital in toughening the ship to resist flooding. They include:

- a. Maintaining the watertight integrity of the ship's subdivision.
- b. Properly classifying closures and fittings.
- c. Properly setting material conditions of closure.
- d. Providing of adequate amounts of well distributed, operable damage control equipment.

5-16. ADVERSE OVERLOADING EFFECTS. Operating at excessively heavy displacement produces the following important detrimental effects:

- a. Speed. Increased displacement increases hull resistance and decreases propeller efficiency and, therefore, reduces speed.

- b. Cruising range. Increased displacement reduces cruising range by increasing the power required for a given speed.
- c. Stability. If the excess loads are carried high in the ship, stability will be reduced.
- d. Strength. Overloading increases the longitudinal stresses imposed on the ship. Extreme overloading, coupled with heavy weather, may lead to structural distress or even failure.
- e. Freeboard. Increased displacement always reduces freeboard. Reduced freeboard will decrease:
 - (1) Reserve buoyancy.
 - (2) Range of stability. Reduced freeboard cuts down the range of stability; this will occur in spite of an excellent initial stability.
 - (3) Seaworthiness. Reduced freeboard to the weather deck makes the ship wetter in rough weather.

Overloading will seriously reduce the ship's power of survival. The adverse effects of overloading have long been recognized. Limiting drafts and limiting displacements are prescribed in paragraph 5-34, along with a warning against overloading.

5-17. LIQUID LOADING. The Trim and Stability Booklet, which is intended for the use of operating personnel, contains the following conditions of loading for this ship:

- a. Light ship condition. This is not an operating condition. It consists of the weight of the ship complete, ready for service in every respect, including permanent ballast (solid and liquid), and liquids in machinery at operating levels, but without any items of consumable or variable load.
- b. Full-load departure condition. In this condition, the ship is fully loaded for its primary mission at its point of departure.
- c. Beaching condition. This is the condition in which the ship should approach the beach for offloading and loading.

5-18. LOADING CONDITIONS. Detailed loading instructions are as shown in the Trim and Stability Booklet for the operating conditions given above.

5-19. LIMITING DECK LOADS. Addition of topside weight reduces stability. Deck loads in excess of the normal loading of the ship (as described in the Trim and Stability Booklet) tend to impair the ability of the ship to absorb damage. Officers should weigh the added risk before permitting these limiting deck loads to be exceeded.

5-20. SELF-INFLICTED DAMAGE. To afford access and provide for operating the ship, watertight boundaries of above-water compartments are pierced by such openings as doors, hatches, and scuttles. Maximum reserve buoyancy can be realized only when all such openings are properly and tightly closed. Reserve buoyancy may be impaired by the crew's actions as well as by accidental or battle damage. The following examples show actions by the crew which lessen the watertight integrity of the ship:

- a. Poor maintenance, resulting in lack of tightness in watertight boundaries, closures, or fittings within the ship.
- b. Failure to close properly such fittings as doors and hatches, which violates watertightness.
- c. Improper, insufficiently rigid damage control classification of fittings.

5-21. ADDITIONAL TOPSIDE WEIGHT. The discussions that follow are relative to additional topside weight and its effect on overall stability:

a. Emergency topside loading of this ship - resulting from deck cargo, taking aboard large numbers of survivors, or icing-up of rigging and superstructure - will impair overall stability because of the consequent rise in center of gravity as well as loss of freeboard. This will reduce the ship's seaworthiness and ability to withstand damage.

b. Decisions to carry emergency deck cargo must be taken with full understanding of the dangers involved and the increased hazard to the ship in the event of damage. Location and magnitude of additional weights can be used to calculate net decrease in stability resulting from a specified deck load.

c. It is possible that the ship may be called upon to pick up large numbers of survivors. The resulting additional topside weight can be a matter of grave concern, particularly if the survivors all come topside and go to one side of the ship simultaneously.

d. Topside structure and rigging ices up in frigid weather, most heavily within 100 miles of the coast. The resulting reduction in stability makes it necessary to maintain the ship in the most favorably ballasted condition. Icing is combated by using jets of steam and/or hot salt water, as well as mauls and axes. The heavy weight increase high in the ship will cause an appreciable rise in the center of gravity. If icing is severe, the ship may have negative initial stability and will loll or capsize.

5-22. STATUS BOARDS. It is required that a liquid loading diagram be posted at the Damage Control Station and at repair stations, showing the status of fuel and water tanks. Some ships use mimeographed copies of the subdivision diagram. Each day the Engineer marks up a new copy. The value of having such a record available is that it shows which compartments contained liquids before damage, hence did not flood. It also provides a chart on which to mark up information on the extent of the flooding as this comes in via communication systems after damage.

Section VI. EFFECTS OF DAMAGE

5-23. NATURE OF DAMAGE. The purpose of this section is to discuss the causes of damage and the impact of damage on the ship.

a. The nature of damage which the ship sustains as a result of battle damage depends on the type of weapon, its size, and the location of the hit.

b. All damage is not inflicted by the enemy. Collisions, groundings, and storms have in many cases caused damage so severe as to threaten the survival of ships. Self-inflicted damage may stem from lack of preparation or neglect, as discussed previously. Some other causes of impaired stability are icing topside, excessive deck load, removal of ballast, overloading, and free surface in ship tanks or bilges.

5-24. ABOVE WATER WEAPONS. The damage which is sustained from above-water attack is initiated in four general ways: penetration of boundaries, blast effect, fragment attack, and toxic gases.

a. Penetration. For penetration, most missiles are fitted with a strong steel case.

b. Blast. Blast effect is obtained by filling the interior of explosive missiles with a bursting charge. The amount of blast produced varies with the weight of the bursting charge, not with the total weight. In a lightly constructed ship, an armor-piercing missile may pass through three or more boundaries before detonating. Occasionally such weapons pass completely through a small ship and detonate in the air beyond it.

c. Fragment attack. The extent of fragment or splinter damage depends both on the thickness (and type) of case and the size of the bursting charge. Hence, greater fragment attack may be expected from a "stinger" type missile than from an armor-piercing projectile. The fragments projected from a missile that undergoes a higher order detonation often have velocities as high as 3,000 or 4,000 feet per second. They may penetrate two or three successive boundaries in a ship of light construction. Secondary fragment effects are produced where passage of the missile or the blast of its explosion tears loose portions of ship structure and hurls them about the ship, often in unexpected directions. In the LCU, above water attack may carry to the engineering plant, cutting the fuel, or lube oil piping and damaging or misaligning the machinery. Engineering repair teams must be prepared to isolate such damage quickly and use the damage control pipe and tank patching kits expeditiously to restore fuel and lube oil to the engines and generators. Likewise, the hull systems (e.g., fire main and drainage) are likely to suffer. Local structural damage may include holes in decks and bulkheads, plus the warping of door and hatch frames so that closed fittings leak and open fittings cannot be closed. Repair teams must be trained in the patching and shoring of decks, bulkheads, door and hatch frames to maintain watertight integrity. Fittings are also sometimes rendered inoperable by fragments.

d. Toxic gases. The detonation of any high-explosive substance liberates smoke and noxious fumes. If confined within the ship, these vapors have a toxic effect on personnel and may cause severe illness or death. The ordinary protective mask gives little protection against such gases within the

ship, since it does not provide a source of oxygen. The fumes from the explosion are frequently augmented by smoke from ensuing fires. To enter and work in such compartments, personnel must wear oxygen-breathing apparatus or an air-line hose mask.

Section VII. STABILITY REQUIRED AND STABILITY AVAILABLE

5-25. STABILITY REQUIREMENTS. In determining the stability characteristics required to ensure that the LCU will be seaworthy in the intact condition and capable of surviving the greatest practical amount of underwater damage, the following factors, among others, are considered:

- a. Heeling effect of beam winds of typhoon force against the intact ship.
- b. Residual stability after damage.
- c. Heeling effect of unsymmetrical flooding after damage.
- d. Reserve buoyancy after damage.

NOTE

For the LCU, the greatest practical amount of underwater damage is limited by reserve buoyancy after damage.

e. The stability characteristics and the reserve buoyancy of these ships are such that a satisfactory condition of stability and reserve buoyancy will exist after the flooding of any one compartment providing:

- (1) The specified limiting drafts are not exceeded before damage,
- (2) The height of center of gravity (KG) is kept at or below the limiting value, and

(3) A proper degree of watertight integrity is maintained. Specifically, the watertight doors to the Bow Thruster Compartment at Frame 17 and the door to the tunnel at Frame 25 must be closed and dogged.

5-26. STABILITY AVAILABLE. The LCU actually has excessive intact stability in all reasonable conditions of loading. This is indicated by the high metacentric height, or GM, shown in one of the typical conditions of loading. Because of this stability, the LCU can withstand an unusual amount of damage without assuming a dangerously large angle of heel.

The short natural period of roll observed in the LCU is a function of its high initial stability. The motion in a seaway is apt to be quick and uncomfortable. The effect of loading cargo high in the ship in an effort to relieve this condition will be negligible for any practical arrangement of loading. Particular care must be taken to secure all cargo adequately to prevent shifting. A change in course or speed, if tactically possible, may reduce the amplitude of rolling.

Information available to evaluate the LCU's stability is provided in the following documents:

a. The Curves of statical stability (intact). The curve of statical stability, and its properties, are an index of the ship's transverse stability of a given condition of loading. These properties include metacentric height (GM), maximum righting arm (GZ) and the angle of inclination- Θ at which it occurs, range of stability and dynamic stability. For the LCU, the beaching condition and the full-load departure condition represent the upper and lower limits of the operating range. Curves of intact statical stability for these conditions are shown in the Trim and Stability Booklet. On rare occasions such as entering dry-dock or when lightened for retraction from a beach, the ship may approach light, condition; a curve for this case is also shown. It is evident that the range of positive stability is adequate for all normal considerations.

b. Damage stability calculations. At or below the drafts of 7.6 feet above the bottom of keel amidships and 7.74 feet above the bottom of keel at the after perpendicular before damage, calculations indicate that these LCUs should be able to survive the flooding of any one compartment without loss by foundering or capsizing. As an indication of the effects of a typical single compartment damage, the calculations after damage are furnished in the Damage Stability Booklet. Calculations are shown for the beaching, full-load departure, and full-load arrival conditions. Calculations indicate that the fully loaded ship will survive flooding of multiple tanks as follows:

- (1) #1 Center Sea Water Ballast and #2 Port (or Starboard) SWB.
- (2) #2 Port (or Starboard) SWBD and #3 Port (or Starboard) FO.
- (3) #3 Port (or Starboard) FO and #4 Port (or Starboard) FO.
- (4) #4 Port (or Starboard) FO and #5 Port (or Starboard) SWB.

Section VIII. MEASURES TO SAFEGUARD STABILITY

5-27. STANDARDS. The ship meets a single compartment standard in conformance with U.S. Coast Guard rules, including the engine room.

5-28. STABILITY CONDITIONS. Several damage stability conditions are analyzed in the Trim and Stability Booklet to provide the ship's personnel an understanding of the LCU's capability to withstand damage resulting in flooding. Two loading conditions are investigated, full-load departure and full-load arrival.

5-29. WEIGHT AND MOMENT COMPENSATION. Any increase in the weight of the ship must be avoided since the single compartment standard must be preserved. Weight compensation by weight removals is required before any weight is added. These removals can be made from any level as stability is not critical.

5-30. LIQUID LOADING INSTRUCTION. Diesel oil may be drawn from any tank in any sequence.

5-31. WATERTIGHT INTEGRITY. The maintenance of watertight integrity is essential to developing full resistance to underwater damage. It is essential to maintain the watertight bulkheads and watertight doors (including doors to main deck storerooms, damage control locker, and the paint locker).

5-32. PROCEDURE AFTER DAMAGE.

CAUTION

Every effort should be made to confine the flooding.

STEP ONE

ESTABLISH FLOODING BOUNDARIES as close to the area of damage as possible.

STEP TWO

DEWATER ANY FLOODED SPACES ABOVE THE MAIN DECK whose boundaries can be made sufficiently tight. First action should be to drain off any flooding water which may have entered the main deck storerooms if this can be made sufficiently watertight.

STEP THREE

SIZE UP THE SITUATION before taking further action. As previously stated, there is every expectation of survival after any single compartment has been flooded, provided the limiting drafts were not exceeded prior to damage. Even after such damage, the principal danger is not the loss of stability but the loss of reserve buoyancy. Under any condition of damage in which the ship remains afloat, there is little danger of experiencing a negative metacentric height. The principal task, therefore, is to regain buoyancy.

STEP FOUR

ELIMINATE OR REDUCE LIST. Since the SW Ballast Tanks 1 and 2 are not cross-connected, it is expected that the ship will develop a 7-10° list after damage to one of those tanks. Assuming that the spaces above the main deck have been dewatered to the greatest possible extent, the next action should be to drain any low spaces which may be PARTIALLY full. If circumstances permit, this procedure may be applied to diesel oil as well as any damage water which may have entered these spaces. If any spaces below the main deck are COMPLETELY full, they are best left alone for the time being.

After these preliminary operations have been carried out, attention may be turned to further reduction of list. Since any list after damage will be due probably to shifting of solid weight rather than negative metacentric height, the problem is a relatively simple one for the LCU. There are several methods of reducing list and these are indicated below in the approximate order of desirability for the LCU. In general, any method which involves a lightening of displacement should be favored over one which would increase displacement, particularly if structural damage has been severe or if bad weather is prevailing at the time.

The order of procedure in this operation is to apply a transverse moment in the opposite direction to the unsymmetrical load of EQUAL OR SMALLER magnitude. This may be done by:

- a. Emptying a tank on the low side into the sea. The moment correction is the figure given on the Liquid Loading Diagram (assuming the tank was completely full and is completely drained).
- b. Shifting liquids from the low side to the high side. The transverse moment in this case is the sum of the moment of the tank drained and the moment of the tank filled (assuming spaces are completely drained and completely filled).
- c. Jettisoning topside weights on the low side. The transverse moment correction is the weight in tons multiplied by its original distance from the centerline of the ship in feet.
- d. Shifting solid weights (cargo). The transverse moment is the weight in tons multiplied by the transverse travel in feet.

CAUTION

Avoid shifting weight to a substantially higher level or flooding spaces above the main deck. Excess weight high in the ship causes a rise in the center of gravity and subsequent degradation of stability.

It is not always necessary to eliminate the list entirely. In some cases, total elimination of list may be possible only by resorting to filling of tanks on the high side. The consequent increase in displacement would probably offset any advantage to be gained from bringing the ship upright. If the ship is manageable, any additional list correction should be undertaken only after due thought has been given to the problem.

5-33. MINIMUM ACCEPTABLE STABILITY. In order to resist the effects of damage, it is essential that the vertical height of the ship's center of gravity (KG) be kept below a certain value. Calculations indicate that this value is reached when carrying 350 tons of cargo. Therefore, the amount of cargo at departure should not exceed this total.

5-34. LIMITING DRAFT.

- a. Limiting value assigned. A limiting draft of 7.6 feet above the bottom of keel amidships and 7.74 feet above the bottom of keel at the aft perpendicular (1087 tons of displacement) has been assigned to these ships. Distinctive marks have been authorized to be painted on both sides of the ship, representing the above drafts as guides against overloading.

b. Basis of assignment. The factors responsible for the assignment of the above limits on drafts and displacement are as follows:

- (1) Reserve buoyancy.
- (2) Structural strength.

CAUTION

Operating at displacements over the limiting value is detrimental to the safety and performance of the ship in several ways which are briefly summarized below:

c. Dangers of overloading:

(1) Adverse effects on the survival power and safety of the ship:

(a) Reserve buoyancy and floodable length. If the drafts before damage exceed the limiting values, one compartment flooding would probably result in flooding water coming over the main deck aft.

(b) Structural strength. Longitudinal strength is ample for all approved conditions of loading and is not a factor in beaching. Uniform loading of cargo, diesel oil and ballast throughout the length of the ship will result in decreased bending moments and stresses in the hull and decks. The longitudinal bending moment varies as the displacement for a given local distribution and therefore hull stresses will increase in the same ratio. Extreme overloading may raise stresses to a point where structural cracks or even failures will occur, especially in heavy weather. Moreover, if the limiting displacement is exceeded, the reserve of strength available to withstand the effects of damage is reduced.

(c) Transverse stability. If excess cargo is carried high in the ship, safety is impaired by the rise in center of gravity which detracts from every element of stability, namely metacentric height, righting arms, range of stability and reserve of dynamical stability.

(2) Adverse effects on other characteristics:

(a) Speed. Increased resistance at large displacements cuts down the speed obtainable from a given horsepower. If a given speed must be made good, substantial increases in power are sometimes necessary.

(b) Cruising radius. Increased fuel consumption for a given mileage, due to excessive displacement, will reduce the effective cruising radius.

(c) Dryness. Overloading will reduce freeboard to the weather deck, and thus give a wetter and less efficient ship in rough weather. The possibility of superstructure damage and damage to topside cargo from heavy water coming on board must be considered.

Section IX. STANDARD CONDITIONS OF LOADING

5-35. CONDITIONS. In the Intact/Damage Stability Report, nine representative conditions of loading have been calculated to represent the full range of the operating drafts. Usually, these ships will operate somewhere between the full-load departure (with deck containers) and the beaching condition drafts.

The baseline for all calculations, drafts, and functions of form is the bottom of keel amidships. The vertical moments of all load items have been calculated above the bottom of keel at the AP and the result corrected to the bottom of keel amidships.

The reference line for longitudinal calculations is amidships, which is Frame 23.

a. Light ship condition. This condition is the ship complete, ready for service in every respect, including liquids in machinery at operating levels, without items of consumable or variable load.

Weight	575 Tons
Vertical Center of Gravity	10.73 Ft. above Keel @ AP
Longitudinal Center of Gravity	12.16 Ft. Aft of Midships

Included in this condition are:

Fixed Ballast	None
Armament	Two 50-Cal. Machine Guns
Boats	13-ft. Rigid, Inflatable Workboat
	Two Life Rafts

b. Full-load departure condition. This is a typical condition which depicts the loading and the stability characteristics of the ship when fully loaded with cargo at the beginning of an extended voyage. Ballast tanks are empty.

Full-Load Condition - Draft and Stability Characteristics:

Displacement (D)	1087 Tons
Vertical Center of Gravity (KG)	12.53 Ft.
Longitudinal Center of Buoyancy (LCB)	+2.14 Ft.
Longitudinal Center of Flotation (LCF)	-2.40 Ft.
Longitudinal Center of Gravity (LCG)	-0.52 Ft.
Trimming Lever (TL) - LCG - LCB	-2.66 Ft.
Moment to Trim One Inch (MCT1")	860.54 Ft-Tons
Trim Moment - D x TL - 1087 x 2.66 ft.	2,891.40 Ft-Tons

$$\text{Trim} = \frac{D \times TL}{MCT1" \times 12} = \frac{1087 \times -2.66}{860.54 \times 12} = -.28 \text{ Ft.}$$

Draft Mean Midships	7.54 Ft.
Draft Aft	7.68 Ft.
Draft Fwd	7.40 Ft.

c. Beaching condition. This is the condition in which the ship should approach the beach prior to landing. In some cases of damage to the ship, it may not be possible to attain the exact drafts forward and aft which are indicated; an effort should be made to approach this condition as closely as possible. The slope of keel has been established as 1 in 30, which is suitable for the average ocean beach. For steeper or more gentle shelving beaches, this value may require adjustment.

Beaching Condition - Draft and Stability Characteristics:

Displacement (D)	876 Tons
Vertical Center of Gravity (KG)	11.68 Ft.
Longitudinal Center of Buoyancy (LCB)	+2.76 Ft.
Longitudinal Center of Floatation (LCF)	-0.25 Ft.
Longitudinal Center of Gravity (LCG)	-10.13 Ft.
Trimming Lever (TL) - LCG - LCB	+7.37 Ft.
Moment to Trim One Inch (MCT1")	105.91 Ft-Tons
Trim Moment - D x TL - 876 x 7.37	6,456.12 Ft-Tons

$$\text{Trim} = \frac{D \times TL}{MCT1" \times 12} = \frac{876 \times +7.37}{-105.91 \times 12} = -5.08 \text{ Ft. Aft}$$

Draft Mean Midships	6.31 Ft.
Draft Aft	8.84 Ft.
Draft Fwd	3.76 Ft.

Section X. LIQUID LOADING DIAGRAM

5-36. PURPOSE. The purpose of the Liquid Loading Diagram (FIGURE FO-1) is three - fold:

- a. To show the distribution and amount of liquids normally carried on board.
- b. To prescribe the loading which will insure proper conditions of stability and trim.
- c. To show the effect on trim and heel of filling each tank with its normal capacity of liquid.

In the upper left corner appears the normal capacity of the tank in tons. For diesel oil tanks, this would be the weight of oil at 95% full. For ballast tanks, it is the weight of salt water at 100% full, and for fresh water tanks, it is the weight of fresh water at 100% full.

In the upper right corner is shown the change of list that will result from filling each tank to the above capacities. The figures in the lower right and left corners show the changes in draft forward and aft, respectively, to be expected from filling the tank.

Two sets of values for trimming effects are provided, one for the full load departure condition and the other for full-load arrival condition.

Section XI. CURVE OF RIGHTING LEVERS

5-37. INTRODUCTION. FIGURE 5-5 shows the variation of righting arms (GZ), with an angle of heel, for an assumed height of center of gravity (KG) of 11.7 feet above bottom of keel amidships. For any condition of loading in which displacement and KG are known, a curve of intact statical stability can be developed. This curve is for the beaching condition. FIGURES 5-6, 5-7, and 5-8 are for the full-load departure, full-load arrival, and light ship condition respectively.

As an example, the curve of intact statical stability for the beaching condition was developed.

Given	Displacement	876.22 Tons
	KG (Uncorrected)	11.68 Feet
	Free Surface Correction	0.36 Feet
	KG (Corrected)	12.04 Feet

<u>Angle</u>	<u>Righting Arm</u>
10 Deg	3.20 Feet
20 Deg	5.50 Feet
30 Deg	5.74 Feet
40 Deg	5.05 Feet
50 Deg	3.42 Feet

Maximum Righting lever GZ = 5.80 Feet at 27.5 degrees.

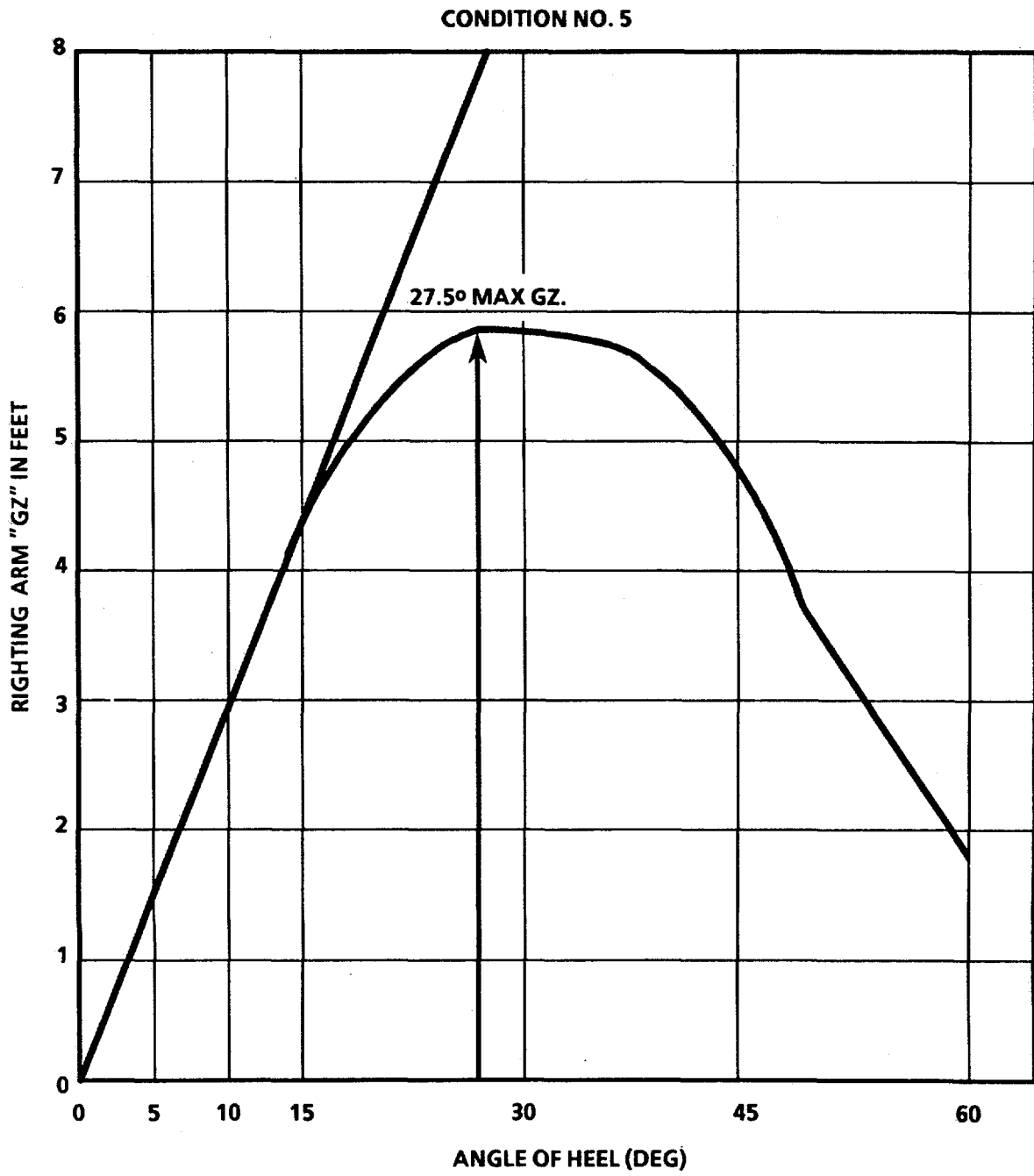

PED/SDC-6

FIGURE 5-5. Curve of Righting Levers - Beaching Condition.

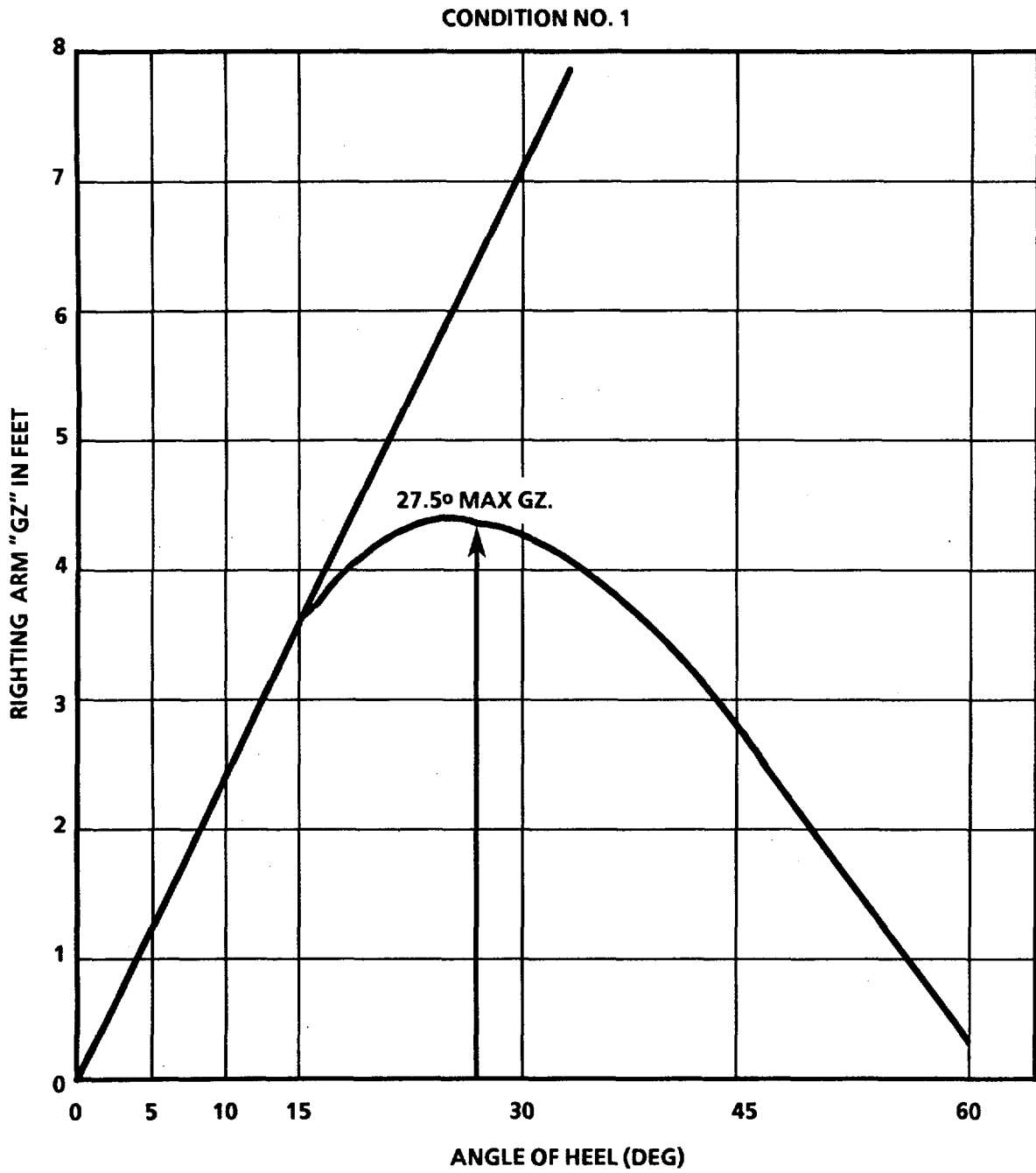

PED/SDC-7

FIGURE 5-6. Curve of Righting Levers - Full-Load Departure Condition.

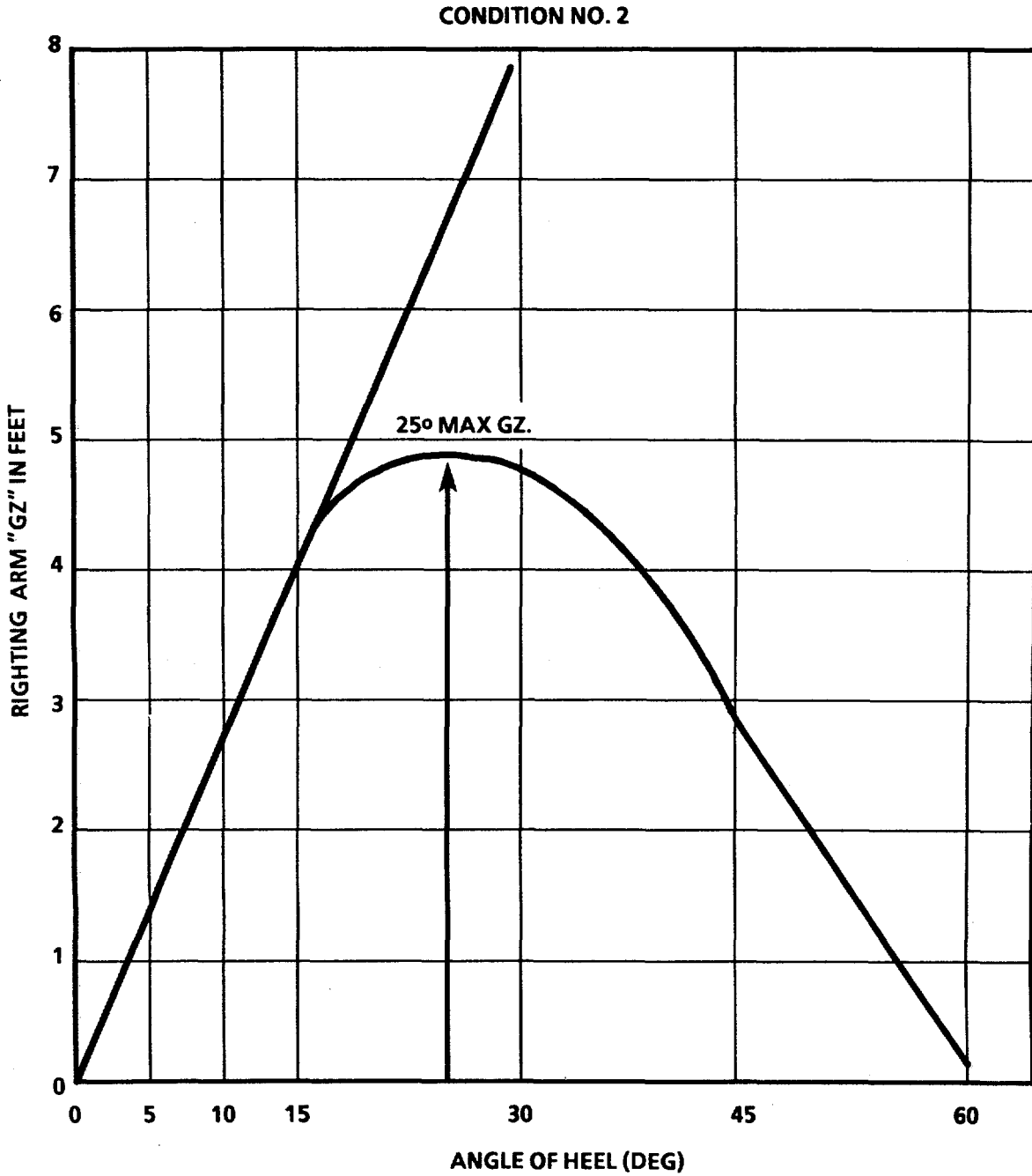

PED/SDC-8

FIGURE 5-7. Curve of Righting Levers - Full-Load Arrival Condition.

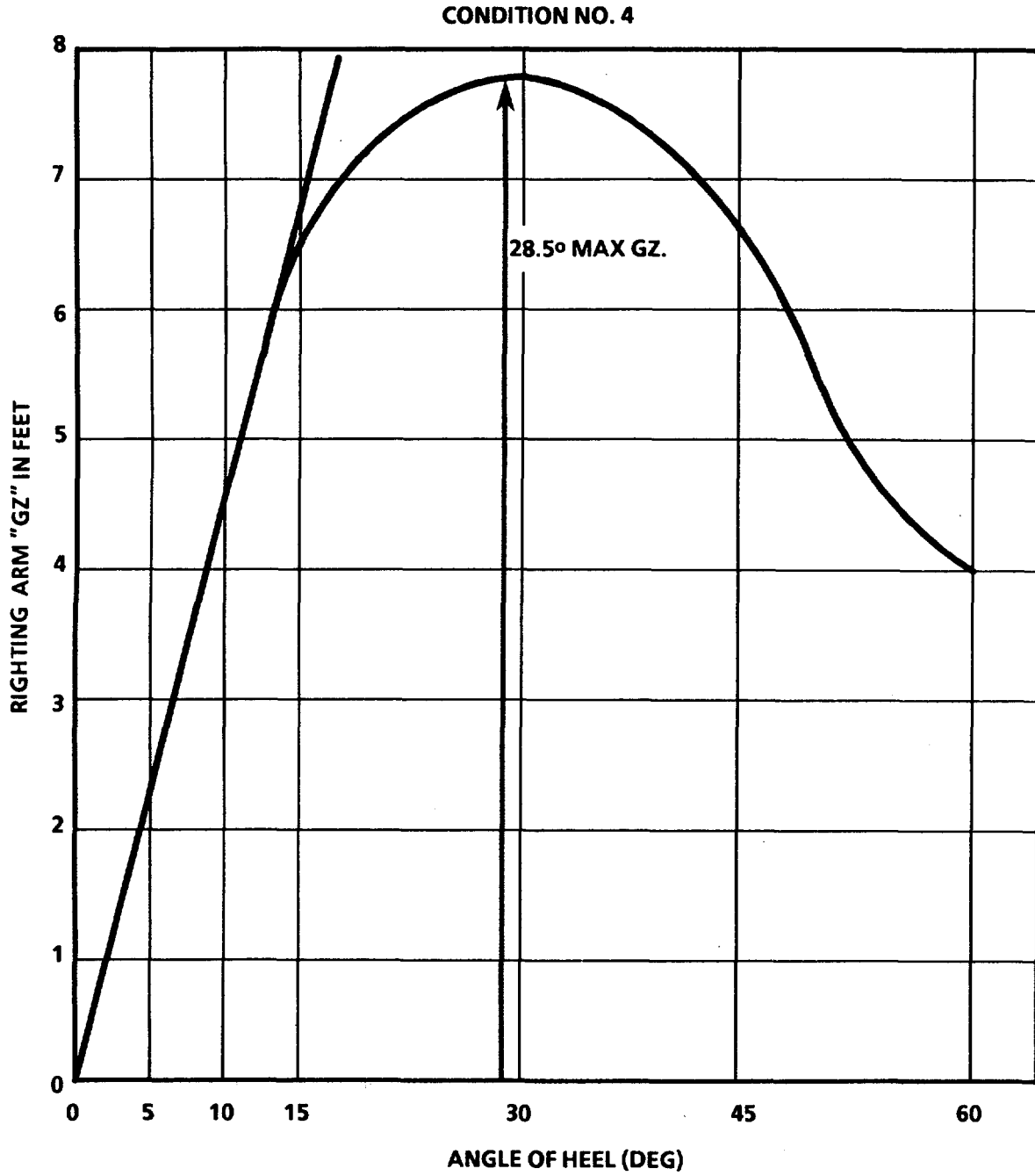

PED/SDC-9

FIGURE 5-8. Curve of Righting Levers - Light Ship Condition.

Section XII. TRIM AND STABILITY BOOKLET AND DAMAGE STABILITY BOOKLET

5-38. INTRODUCTION. The Trim and Stability Booklet contains guidance on loading, tank usage, securing of weathertight closures, and stability calculations used to establish the stability of the ship to realistic and satisfactory accuracy. This booklet will normally be maintained and used by the vessel master. The Damage Stability Booklet contains detailed descriptions of nine different damage cases to illustrate the ability of the ship to survive a wide variety of underwater damages. The vessel's Chief Engineer will normally maintain custody of this booklet.

CHAPTER 6

FIRE

SDC FIXES SHALL BE USED ONLY IN COMBAT OR OTHER EMERGENCY CONDITIONS AT THE DISCRETION OF THE VESSEL MASTER. DAMAGE SHALL BE REPAIRED BY STANDARD MAINTENANCE PROCEDURES AS SOON AS PRACTICABLE.

Section I. INTRODUCTION

6-1. FIRE - GENERAL. Most fires escalate from small points of ignition, such as welding slag igniting cable insulation in the case of an in port event, or an electrical switchboard fault underway. Fire and/or explosion can develop from battle damage. Whatever the cause of the fire, if the proper actions are taken immediately, most fires can be readily extinguished. The smoke, toxic fumes, and heat created by a fire can incapacitate personnel, damage equipment, and reduce visibility, severely hampering firefighting operations. The purpose of this chapter is to discuss the effects of the various fire hazards, to discuss the equipment/systems available to combat fire and to delineate the proper actions to be taken to control them.

Section II. CHEMISTRY AND PHYSICS OF FIRE

6-2. COMPONENTS OF FIRE. The entire chemistry and physics of fire and burning or combustion may be simplified into a relationship between three components: fuel, heat or temperature, and oxygen or air. In order to have a fire in some combustible substance, each one of these components must be present and assisting the others. The firefighter can confront any one or more of the components, remove them, and cause the burning to stop. The type of fire fighting agent which the firefighter has at hand determines which component he is going to remove. Fires in ships are categorized in four classes (A,B,C, and D) which are determined by the general types of fuel involved. It should be kept in mind that most fires will involve a variety of combustibles and therefore may be a combination of all four classes.

Section III. CLASSES OF FIRE

6-3. CLASS A FIRES. Class A fires are fires involving solid combustibles, such as cable insulation, clothing, paper, plastics, upholstery, wool, rags, or bedding.

6-4. CLASS B FIRES. Class B fires involve flammable liquids or gases, such as diesel fuel, hydraulic oil, lubricating oil, and cooking fat. This class of fire can occur when leaks in pressurized piping spray oil on hot surfaces or from malfunctioning electrical components within the oil systems. Fires in deep fat fryers result from overheating of cooking oils and subsequent ignition of the fat.

6-5. CLASS C FIRES. Class C fires are fires in energized electrical equipment. These fires have occurred due to shorts, arcing or sparks associated with loose connections, deteriorated wiring, oil-soaked wiring, and negligence in maintenance of electrical equipment. When the affected equipment is completely deenergized, the fire becomes either Class A or Class B.

6-6. CLASS D FIRES. Class D fires are fires involving combustible metals. Magnesium metal is a combustible (Class D) fuel aboard ship when it becomes heated to a high temperature. This fuel burns with a dazzling white flame of very high temperature. At this temperature it reacts chemically in the white flame area with ordinary extinguishing agents such as water, and special methods have been devised to cope with it. In general, magnesium metal fires are extinguished only by smothering with dry sand, by a cooling action using large amounts of water from a safe distance, or by spraying water on the unburned metal behind the flame so that its temperature is lowered and burning can no longer continue.

Section IV. PRODUCTS OF COMBUSTION

6-7. GENERAL. The products of combustion are fire gases, flame, heat, and smoke. These products have a variety of physiological effects on humans, the most important being burns and the toxic effects which result from the inhalation of heated air gases.

6-8. FIRE GASES. The term "fire gases" refers to gaseous products of combustion. Most combustible materials contain carbon, which produces dangerous carbon monoxide when the air supply is poor. Unless the fuel and air are premixed, the air supply in the combustion zone is usually poor. When materials burn, numerous other gases are formed, such as hydrogen sulfide, sulfur dioxide, ammonia, hydrogen cyanide, phosgene, hydrocarbons, and hydrogen chloride. Gases formed by a fire depend on many variables, principally the chemical composition of the burning material, the amount of oxygen available for combustion, and the temperatures.

Several variables determine whether the gaseous products of combustion will have a toxic effect on an individual, including concentration of gases in the air, the time of exposure, type of activity, and the physical condition of the individual.

The toxic effects on persons inhaling fire gases are greater during a fire because the rate of respiration is increased by exertion, heat, and an excess of carbon dioxide. The primary cause of loss of life in fire deaths is inhalation of heated, toxic, and oxygen-deficient fire gases.

a. Carbon monoxide is not the most toxic of fire gases but is always one of the most abundant. In a confined smoldering fire, the percentage of carbon monoxide is usually greater than in a well-ventilated, brightly burning fire. (See FIGURE 6-1.)

b. Ammonia is formed when acrylic plastic or phenolic and melamine resins are burned. Exposure to 0.25 to 0.65% ammonia gas for one-half hour can cause death.

c. Hydrogen cyanide is highly toxic and is formed when urethane, nylon, or melamine are burned. Breathing a concentration of 0.3% is fatal. It can also be absorbed through the skin, causing the same results. The characteristic bitter almond odor sometimes warns of hydrogen cyanide presence.

d. Hydrogen chloride is a fire gas produced during the combustion of chlorine-based plastics such as PVC electrical cable insulation. It is absorbed in smoke and, when breathed, desorbs as hydrochloric acid deep in the lungs. It can cause death due to lung edema.

e. Phosgene gas is highly toxic and is produced when polyvinyl-chloride, refrigerant, or other chlorinated compounds are involved in a fire.

6-9. FLAME. The burning of materials in the presence of a normal oxygen-rich atmosphere is generally accompanied by flame. For this reason, flame is considered a distinct product of combustion. Burns can be caused by direct contact with flames or heat radiated from flames. It is rarely separated from the burning materials by an appreciable distance. In certain types of smoldering fires without evidence of a flame, heat and smoke and gas can develop. Air currents can carry these elements far in advance of the fire.

6-10. HEAT. Heat is the combustion product mostly responsible for the spread of fire. It poses dangers that range from minor injury to death. Exposure to heated air can cause heat exhaustion, dehydration, blockage of the respiratory tract, and burns. Exposure to temperatures above 1300 F without respiratory protection is extremely hazardous. One or two breaths of moisture-saturated air at such temperatures can cause serious respiratory system damage.

6-11. SMOKE. Smoke is matter consisting of very fine solid particles and condensed vapor. These combustion products are usually evolved from the combustible with sufficient velocity to carry with them droplets of flammable tars which appear as smoke. Smoke provides the warning of fire and simultaneously contributes to the fear of those in the smoke by the nature of its blinding and irritating effects. Smoke causes eyes to water, which impairs vision and also causes irritation to the respiratory tract and uncontrollable coughing.

6-12. ASH. Ash is the residue of burned materials. It can contain any chemical that results from the burning of basic fuel such as hydrogen chloride and carbon fibers. It may also contain residue from fire extinguishing agents (i.e., dry chemicals).

Section V. FIRE HAZARDS OF MATERIALS

6-13. FIRE HAZARD MATERIALS. Several materials than can support a fire are briefly discussed here.

a. Cable insulation. Most cable insulation contains a large quantity of polyvinyl chloride (PVC) which will sustain combustion at 680° F when decomposed in a fire. PVC will liberate hydrogen chloride and hydrogen cyanide gases when heated to about 390° F. These gases interfere with vision, cause intense respiratory irritation, and may cause death due to lung edema 12 to 36 hours later. The best way to extinguish this type of fire is to bring water

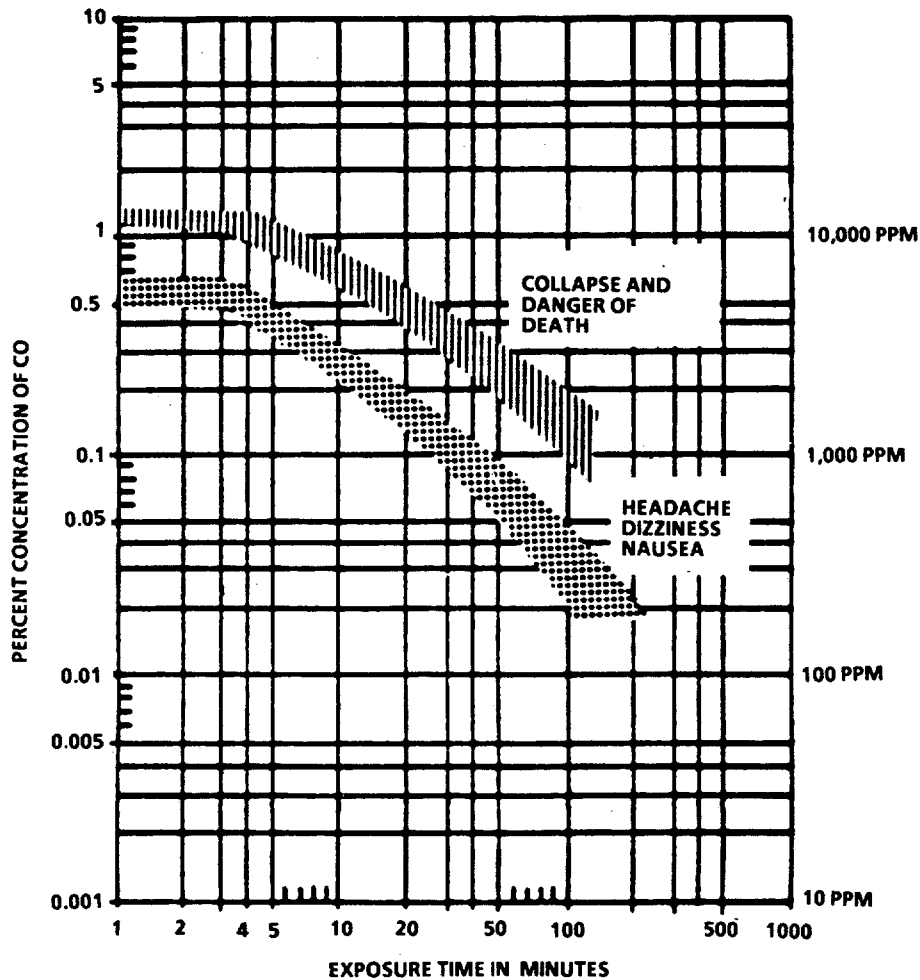

1. The graph shows the effects of carbon monoxide on man as functions of concentration and exposure time. Milder effects are shown as a lightly shaded band of exposure times and concentrations while dangerous or lethal times and concentrations are grouped in the heavily shaded band.
2. The effects on personnel may be greatly increased by requirements for physical exertion.
3. Recovery from high concentrations of carbon monoxide may not be free from residual damage to nerve centers and other tissues.

FIGURE 6-1. Effects of Carbon Monoxide on Personnel.

to bear in the form of water fog. In the interim, Aqueous Film Forming Foam (AFFF) is most effective against this type of fire. If power to the affected cables is completely deenergized, this type of fire is considered a Class A fire.

b. Diesel fuel. Diesel fuel has a flash point of 140° F and an auto ignition (ignition without the assistance of an external pilot source) temperature of 400° F. When ignited, it will produce a heavy black smoke. The fire should be attacked using AFFF. If AFFF is not available, use dry chemical extinguishers. Low-velocity water fog should be available when setting the reflash watch.

c. Hydraulic oil. Hydraulic oil has a flash point of about 400° F and an auto ignition temperature of over 650° F. If hydraulic oil at 3,000 psi is atomized from a leak in a pipe, it will readily burn if exposed to an ignition source. Laboratory tests indicate that the oil mist fire will continue to burn even if the ignition source is removed when the oil is at the normal operating temperature of 110° F to 130° F. A hydraulic oil fire can ignite surrounding combustibles such as cable insulation and produce intense heat once its ignition temperature has been reached. Such a fire will cause a pressure increase in a sealed compartment. Hydraulic oil spray/mist fires should be attacked with dry chemical fire extinguishers. AFFF should be used against two-dimensional fires. If the fire is an oil mist, the extinguisher should be aimed at the base of the fire until the flame is extinguished. This will interrupt the fuel flow to the fire. If the fire cannot be extinguished by dry chemical extinguishers, water should be brought to bear. Dry chemical extinguishers do not cool a fire; therefore, reflash can be expected. Low velocity water fog should be available when setting the reflash watch.

d. Oil mist. If an oil leak mist accumulates before an ignition source is introduced, later ignition can result in an explosion. It is important to secure and/or depressurize the source of the leak as soon as possible and avoid actions that could cause an arc, sparking, or open flame before the mist is dispersed.

e. Vegetable oil. The vegetable oil used in cooking has a smoke point of 420° F, a flash point at 10° F to 20° F higher, and an autoignition temperature of about 600° F when fresh. Respective temperatures are much lower when the oil has been used. If installed, the aqueous potassium carbonate system should be used to extinguish a deep fat fryer fire. If not, AFFF or PKP extinguishers should be used, applying the AFFF continuously or the chemical in short bursts of 3 seconds to extinguish flames. Repeat if oil reignites. The range exhaust hood damper should be closed immediately. As soon as a fire hose with a low-velocity fog applicator is charged, apply water fog simultaneously with a 3-second PKP extinguisher discharge if the fire is still burning. If the oil reignites, repeat this procedure. Low-velocity fog should be maintained available for the reflash watch.

f. Gasoline. Fires involving gasoline fuel can be extinguished only BY smothering. CO₂ provides only temporary smothering and, the flammable vapors which continue to evolve from these fuels at ordinary temperatures can easily be reignited causing the fire to begin all over again. Dry chemical agents provide a more permanent smothering effect and should be utilized to avoid

reignition. Since water does not mix with these fuels, nor does it stop evolution of flammable vapors, water alone usually causes flammable fuel fires to spread dangerously.

g. Paper products. Paper products constitute one of the larger fire loads, but if good housekeeping is observed, there is a low potential for a large fire.

Section VI. EXTINGUISHING AGENTS

6-14. TYPES OF AGENTS. The extinguishing agents dispensed from hand-held equipment and which are used on ships are water, carbon dioxide (CO₂), dry potassium bicarbonate chemical (PKP), and Aqueous Film Forming Foam (AFFF).

a. Water. Water is, and has long been, the most commonly used extinguishing agent. Water lowers the temperature of a burning substance below its ignition point. Water brought to bear on a fire can be in the form of high velocity fog, low-velocity fog or solid stream using the all-purpose nozzle. Extensive fire tests have shown that the all-purpose nozzle with the low velocity fog applicator is the best nozzle for ship use. Using water in the form of water fog greatly increases the surface area and consequently the rate of heat exchange between the burning material and the water. This heat exchange produces steam, which has a smothering effect on fire.

(1) High-velocity fog. High-velocity fog allows the firefighter to attack the fire from a greater distance and will cause cool air to be drawn toward the fire past the firefighter. High-velocity fog shields the fire-fighter from heat, thus protecting from fire exposure. However, the high-velocity fog tip will also introduce more water, which is not desired in most cases. See FIGURE 6-2. The all-purpose nozzle was designed to operate at 60 to 100 psi and, when used at the minimum pressure, the high-velocity tip does not perform as well as the low-velocity fog based on a study conducted by the Navy. The Navy reports a 27-square-foot pan fire could not always be extinguished using high-velocity fog but could be extinguished consistently using low-velocity fog. See FIGURE 6-3.

(2) Low-velocity fog. Using a 4-foot low-velocity water fog applicator, the firefighter can reach over or around obstructions to apply a cooling, smothering blanket of fog on the fire. The all-purpose nozzle, when equipped with the applicator and fog-head, projects (FIGURE 6-4) a fog having the maximum of diffusion. The fog pattern from the fog-head is at its most effective dimensions 5 or 6 feet from the tip of the applicator. It also precipitates and dissolves smoke and fire products while providing a cool path advancing on the fire. On the LCU, low velocity fog applicators are located at Fire Stations 1 and 2 in the Machinery Space.

Using water in the form of low-velocity fog to put out electrically caused fires is acceptable when two portable extinguishers have not put out the fire. It is assumed that an effort has been made to deenergize electrical equipment; however, research has not revealed any cases of electrocution due to the application of a low-velocity fog on shipboard electrical fires. The primary concern when using water on an electrical fire is damage to equipment by sea water. Using the low-velocity fog applicator speeds extinguishment, decreases

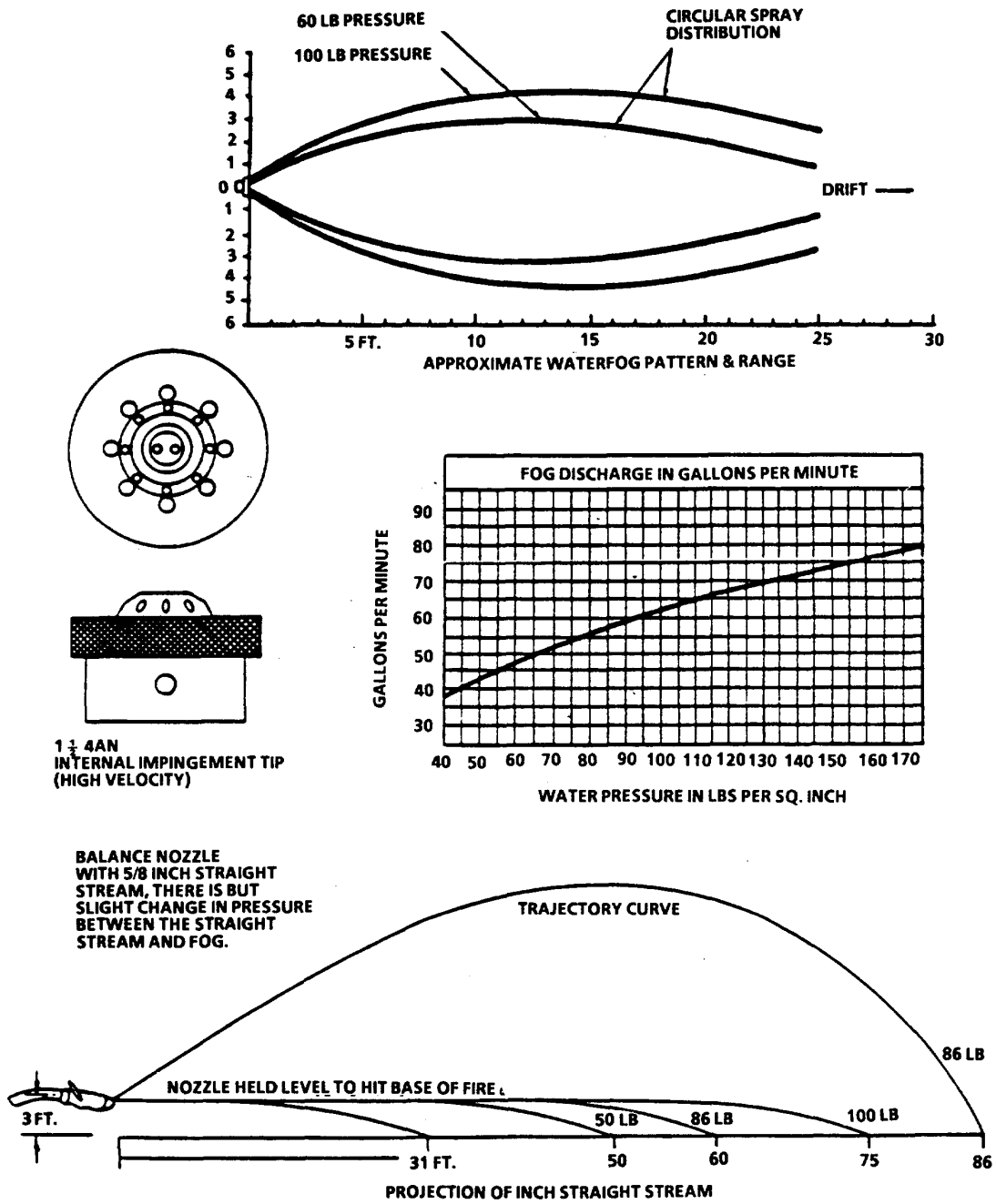

PED/SDC-12

FIGURE 6-2. High-Velocity Fog Pattern.

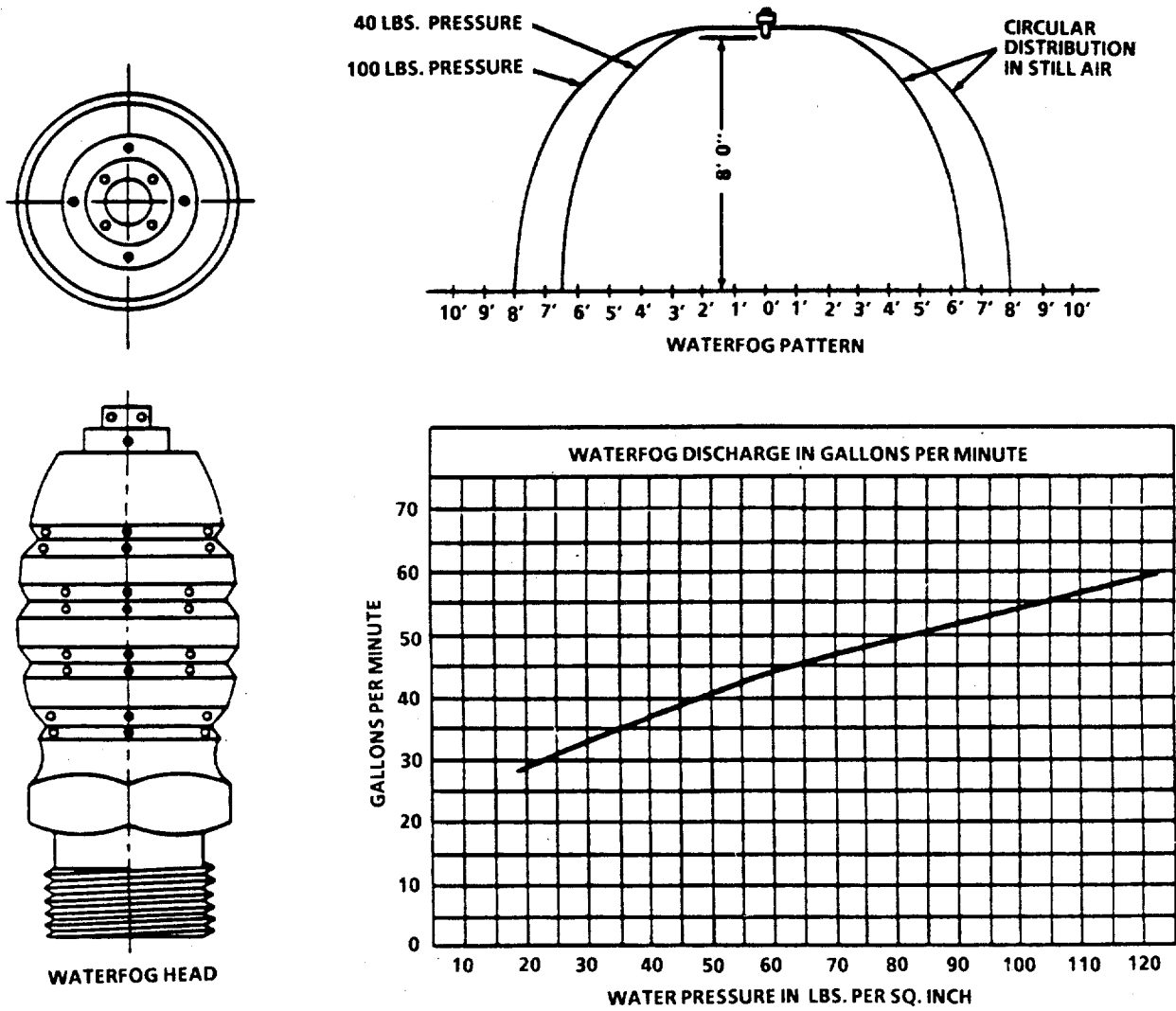

FIGURE 6-3. Low-Velocity Fog Pattern.

the amount of water used, and minimizes the water damage to equipment not involved in the fire.

Water in the form of a solid stream is not a preferred method of water use on board ships. It is not as efficient as fog and can add large quantities of water to an area which must eventually be pumped out. The splashing effect of the solid stream also tends to cause damage to surrounding equipment.

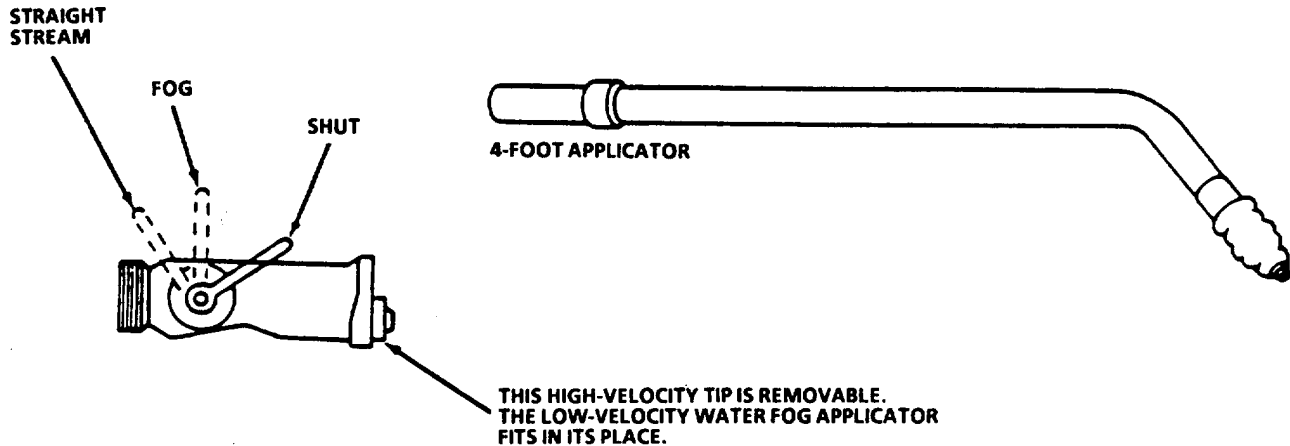

FIGURE 6-4. All-Purpose Nozzle.

b. $C0_2$. $C0_2$ is effective as an extinguishing agent primarily because it reduces the air to a point where it will no longer be capable of supporting combustion. As a rule, one pound of $C0_2$ will make inert 14.5 cubic feet of space. Prolonged breathing in an atmosphere of high $C0_2$ concentration, about 2 to 3 percent, can cause headaches and nausea. High concentration will cause suffocation, very much the same as immersion in water does when a person drowns. Since $C0_2$ is 1-1/2 times heavier than air, it does not rise, but remains close to the surface in a deep or shallow pool, according to the area covered and the amount of $C0_2$ used. With a portable $C0_2$ extinguisher, there is little danger, inasmuch as its 35 cubic feet of $C0_2$ in the average compartment lies in shallow pools, lower than the average breathing height. $C0_2$ is a dry, noncorrosive gas that is inert when in contact with most substances. $C0_2$ does not cause damage to equipment.

CO₂ is most suitable for combating Class B and Class C fires; however, its smothering action is a temporary one and because little cooling is accomplished, the firefighter must remember that the fire will rekindle if the oxygen is supplied again in the presence of an ignition source. CO₂ extinguishers have an effective range of about 3 to 5 feet.

c. Dry potassium bicarbonate chemical (PKP). Dry potassium bicarbonate chemical, usually called PKP (Purple K Powder), is nontoxic, noncorrosive, and nonabrasive. It can be used effectively on Class B fires and is four times more effective than equal weights of CO₂ in extinguishing flammable liquid fire. Dry chemical is also effective on Class C fires. Smothering and heat radiation shielding contribute to the extinguishing efficiency of potassium bicarbonate; although the exact mechanism is not known, studies suggest that a chain breaking reaction in the flame may be the principal cause of extinguishment. Potassium bicarbonate has little effect on lowering the temperature of the burning material below the ignition point; therefore, repeated applications may be necessary to prevent reflash. PKP is the most effective hand held extinguisher in combating an oil spray fire. The effective range of this agent is 13 to 22 feet in comparison to 3 to 5 feet for CO₂ type extinguishers. Potassium bicarbonate also covers a much larger area; however, this agent leaves behind a residue while the other agents do not. Long discharges will reduce visibility and render breathing difficult. When approaching a fire, a quick squeeze on the nozzle grip will give some assurance that the chemical is not caked and will also knock down some smoke. If two PKP extinguishers are spent and little or no progress is made in extinguishing the fire, the firefighter should proceed to use low-velocity fog.

d. Aqueous film forming foam (AFFF). Aqueous Film Forming Foam, more often called AFFF, is a 6% solution of fluorinated surfactant (detergent) in 94% water. It is nontoxic but highly detergent. It is intended for use on Class B and Class A fires. The extinguishing action of AFFF stems from its ability to make water float on liquid fuels which are lighter than water. As the AFFF is discharged and the agent covers the fuel, the aqueous film floats over the fuel surface and provides a vapor seal. The LCU's foam system consists of a 695 gallon foam concentrate tank and two foam proportioners located in the machinery space between Frames 26 and 28 just inboard of the starboard bulkhead. The proportioners are activated locally in the machinery space. Once activated, the entire fire main is supplied with foam, including the fire monitors.

Section VII. PORTABLE FIRE EXTINGUISHERS

6-15. GENERAL. Most fires are small at origin and in the typical ship are rapidly discovered. They can be easily extinguished if the appropriate application method, proper type, and amount of extinguishing agent are readily available and promptly applied.

Section VIII. OPERATION OF FIRE EXTINGUISHERS

6-16. CO₂ EXTINGUISHERS. CO₂ extinguishers are most effective when used at a distance of 5 feet or less from the outer tip of the horn to the edge of the fire. When using CO₂ extinguishers, the firefighter should get as close to the fire as possible for maximum effectiveness and should fight the fire until

the fire is out and cool enough not to reflash. The most commonly used method of application is to start at or near the edge of the fire and direct the discharge in a slow, side-to-side sweeping motion, gradually progressing toward the base of the fire. CO₂ application should be continued (even after the flames appear to be extinguished) to allow added time for cooling and to prevent any reflash from adjacent hot surfaces or open fingers of flame.

On fires involving electrical equipment, discharge should be directly into the source of the flames. It is important to de-energize the equipment as soon as possible to eliminate the potential source of reignition.

WARNING

Care must be taken when transporting a CO₂ extinguisher; at 80° F the bottle has a pressure of about 1,000 psi. If the valve is broken, it will cause the bottle or valve to become a missile, causing serious personal injury.

A used fire extinguisher should be returned to the Damage Control Locker where it should be recharged if possible or clearly and obviously labeled to identify the fact that it needs to be recharged. A good practice is to remove the horn and hose assembly to prevent attempted use of an empty extinguisher. Replacement extinguishers should be returned to the appropriate storage rack as soon as possible.

NOTE

The lead seal should be checked on all fire extinguishers before being passed into an affected compartment to ensure an empty bottle is not sent to the fire.

6-17. **PKP EXTINGUISHERS.** Potassium bicarbonate (PKP) is carried in 10-pound portable extinguishers on board the LCU. When fighting a surface fire, aim the discharge at the base of the flames and apply in a rapid, side-to-side, sweeping motion, gradually progressing toward the base of the fire. PKP discharge causes a clouding effect which will reduce visibility and will render breathing difficult. Small Class B fires can be quickly extinguished by PKP fire extinguishers but, unless the ignition source or fuel is removed, flame flash-back could be experienced. A backup fire hose with low-velocity fog applicator should always be made available as quickly as possible. PKP can be used simultaneously with water.

CAUTION

A PKP fire extinguisher should not be laid on its side when in use. This will cause the gas expellant to be released and not the potassium bicarbonate.

If the fire persists after expending two PKP extinguishers with little or no effect, low-velocity fog should be used. Low-velocity water fog is superior to PKP on Class A and Class B fires.

6-18. AFFF. Aqueous Film Forming Foam (AFFF) is carried in 2-1/2 gallon, 28-pound portable extinguishers. When fighting flammable liquid fires, aim the discharge at the base of the flame and apply it in a slow, steady side-to-side sweeping motion so that the liquid overruns the fire surfaces, establishing and maintaining the film that smothers the fire. After the film is established, do not break it by splashing the stream on the film surface. In the case of a Class A fire, the stream should be pointed directly at the source of the flames to penetrate and cool the fuel. The effective range of AFFF extinguisher discharge is 15 to 20 feet from the nozzle to the base of the fire. The 695 gallon foam tank contains sufficient foam to cover the main deck two times with 6 inches of foam.

Section IX. BASICS OF FIGHTING FIRE

6-19. GENERAL. While firefighting techniques cannot be set forth in any chronological pattern, the following basic rules apply to nearly all situations:

- a. Isolate the fire. Close all doors, hatches and vents, and secure blowers. All flammable liquid system piping in the affected area should be isolated from damage control deck.
- b. Shut down electrical circuits in the compartment where the fire is located and in adjacent spaces to be sprayed or flooded.
- c. Bring required firefighting equipment to the scene.
- d. Lead out two hoses from different plugs, when practical, to the area of the fire; rig one hose with an applicator, and charge both hoses.
- e. Station a crewman with OBA, gloves, and head lamp, to control the nozzle for each of the two separate hoses.
- f. Station a backup crew member with OBA, electrically safe rubber gloves, and head lamp to relieve the crewman on the nozzle or perform rescues.
- g. Set fire boundaries in surrounding compartments and topside by rigging extra hoses to cool decks, overheads and bulkheads, and by removing combustible materials.
- h. Rig portable pumps which can be used if fire main pressure is lost.
- i. Station crew members at arms room sprinkler controls.
- J. Combat the fire from the best position possible to protect personnel; approach a topside fire from windward, if possible. Consideration should also be given to approaching the fire from the bottom, if possible.
- k. In compartments fully involved with fire, the firefighter should reduce the heat and flame before entering by liberal application of water fog through doors and air ports into upper areas of the compartment. In such a

fire, the greater part of the water fog so applied will turn to steam, thereby smothering the fire as well as reducing heat. The firefighter should stand clear of openings since there may be a violent outward rush of hot gases and air due to their being displaced by steam.

1. In determining the number of hose lines to be used, the firefighter should be guided by the extent and intensity of the fire. The ship's pumping capacity is not unlimited, and every gallon of water released in the ship reduces its stability and freeboard until pumped out. The all-purpose nozzle permits the firefighter to use water fog for nearly all firefighting situations where water is indicated and still have a solid stream available when needed. A solid stream from a 1-1/2 inch hose equipped with the all-purpose nozzle and with 100 psi at the fire main will discharge 250 gallons per minute (gal./min.), while high-velocity fog under the same conditions will discharge only approximately 117 gal./min. Ultimately, every gallon of water put on a fire must be removed to preserve ship stability.

m. It may also be impossible to approach a fire in a space in a normal manner due to heat intensity, blocked hatch, etc. In such a case, it may become necessary to cut an access hole large enough to insert an equipment nozzle in order to apply an extinguishing agent.

n. Send out investigators to check surrounding areas; inspection and reporting must continue until the fire is out and danger is over.

o. Keep phone talker as close to the scene as possible.

p. Make continuous progress reports to the bridge. These shall include:

- (1) Location of fire.
- (2) Class of fire.
- (3) Electrical power secured.
- (4) Fire boundaries set (location).
- (5) Fire under control.
- (6) Fire out.
- (7) Reflash watch set.
- (8) First oxygen and explosive tests.
- (9) Fire overhauled.
- (10) Second oxygen and explosive tests.
- (11) Compartment desmoked.
- (12) Third oxygen, third explosive and toxic tests.
- (13) Compartment safe to enter.

- (14) Electrical circuits and ventilation systems tested.
- (15) Amount of damage done.
- (16) Electrical power restored or isolated.

WARNING

Crew members without OBAs will not enter a compartment prior to the compartment being tested as safe to enter. Serious personal injury to crew members could result.

q. If CO₂ is directed into a fire so that sufficient oxygen to support combustion is no longer available, the flames will subside. Depending on the fuel, this action will take place when the normal 21 percent oxygen in the air is diluted with CO₂ to 15 percent oxygen or less. Some Class A fuels require that it be reduced to less than 6 percent oxygen in order to extinguish glow- ing embers. The smothering action of CO₂ gas is temporary, however, and the firefighter must remember that the fire will quickly rekindle if the oxygen is supplied again in the presence of an ignition source. The temperature of the burning substance and its surroundings must be lowered below its ignition temperature if the fire is to remain extinguished.

A compartment is dangerous and hazardous to life when it is filled with CO₂ due to the lack of oxygen; it shall not be entered unless the party is wearing OBA. In the use of small portable CO₂ extinguishers, the quantity of gas released from one or several of these cylinders is not usually sufficient to reduce the total oxygen content of the air in a compartment to a dangerous minimum. Therefore, the firefighter has basically to consider only the speed with which he can apply CO₂ from these to the fire.

If CO₂ is applied quickly, the fire will go out immediately. It should be applied to the base of the fire, in a sweeping motion. In continuous operation, the 15-pound cylinder will be expended in about 40 seconds. A discharged cylinder must be turned in to the designated area for recharging.

While CO₂ extinguishers are designed for hand application, they can be used in a small compartment as a means of providing partial flooding. Two or three portable CO₂ extinguishers can be placed in the compartment with their valves open. With the doors and ventilation secured, the CO₂ will settle and form a blanket over the lower portion of the compartment. One 15-pound cylinder will cover the bottom of an 11-foot by 12-foot compartment to a depth of approximately 1 foot.

Section X. LCU FIRE MAIN

6-20. GENERAL. The fire main system (FIGURE 6-5) is made up of two electrically driven pumps and one diesel driven pump.

a. Fire pumps. The two electric fire pumps, located in the machinery space just forward of the starboard main diesel, are rated at 250 GPM with a discharge head of 125 psi. The auxiliary fire pump is located in the bow thruster room and is driven by the bowthruster diesel engine. It is rated

500 GPM with a discharge head of 125 psi. Local start/stop control for all pumps is provided. Additionally, each pump can be controlled from the pilothouse.

b. Fire monitors. Two fire monitor stations are provided and located on the top of the pilothouse to provide 360° coverage of the ship. Each monitor is rated at 500 GPM with a 100 psi discharge. The monitors are capable of directional and elevation control and can dispense both water and foam.

c. Fire stations. Fire stations, located throughout the vessel, provide 50 feet of 1 1/2 inch hose, a spanner wrench, and nozzle. Stations are located as follows:

(1) Internal fire stations.

<u>Number</u>	<u>Location</u>
1	Machinery Space, Port side, Forward
2	Machinery Space, Port side, Aft, On Engine Operating System
5	Machinery Space, Starboard side, Forward
6	Main Deck, Port side, just outside paint locker door
7	01 Level Aft Passageway, Athwartships Passage
9	Bowthruster Tunnel, Starboard side, Forward

(2) External fire stations.

<u>Number</u>	<u>Location</u>
3	Main Deck, weather, Starboard side,
4	Main Deck, weather, Port side,
8	Weather deck, 02 level, Frame 36

d. Sprinkler system. The Arms Control Room is fitted with sprinkler and alarm systems. The alarm signals when water is present in the dry side of the sprinkling system. A water switch is installed in the piping on the downstream side of the sprinkler control valve. The switch is connected to activate audible and visual alarms in the Pilothouse if water is present in the sprinkler line due to opening of the sprinkler valve or leakage past the valve. There are 2 sprinkler heads installed in the Arms Control Room. Activation of the sprinkler system can be made from the sprinkler control valve just outside the Arms Control Room or on the bridge.

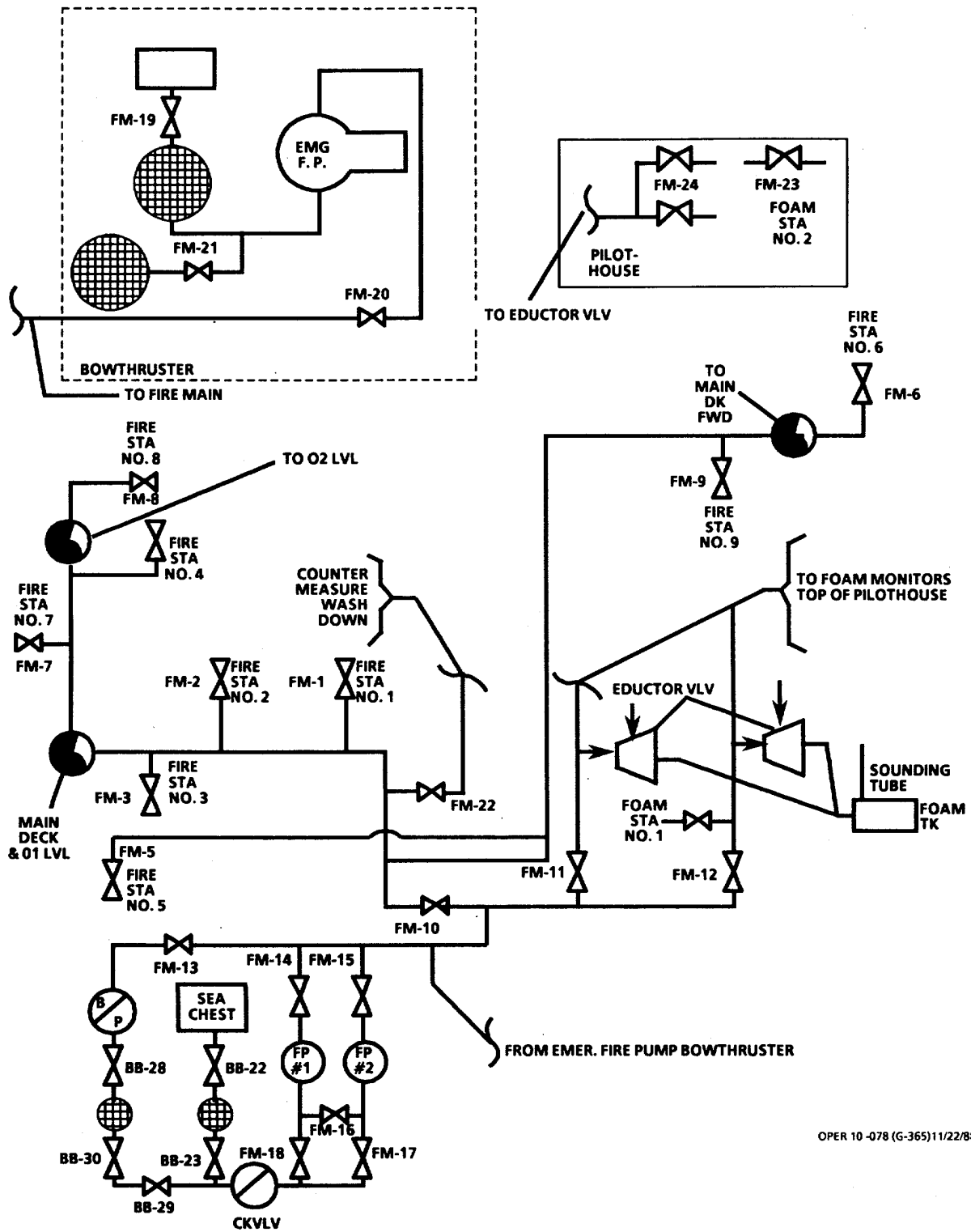

OPER 10-078 (G-365)11/22/88

FIGURE 6-5. Fire Main System.

e. Isolation valves. Isolation valves at various locations allow segments of the main to be segregated and the pumps to be isolated from the sea chests on the main.

6-21. WASHDOWN SYSTEM. The LCU has an installed countermeasure washdown system which will form an umbrella of sea water over the superstructure when activated for protection against nuclear, biological, and chemical (NBC) contaminants. Additional coverage of the cargo and forecastle decks can be accomplished by attaching hoses to weatherdeck fire stations, and strategically placing the nozzles to gain maximum coverage. Nozzles should be in the high velocity fog position and securely lashed to a stationary object. If possible, these hoses should be controlled from below deck cut-out valves when a NBC attack is imminent.

If time allows, the ship should be wet down before a NBC attack. NBC agents which strike a ship already covered with a film of flowing water are normally washed overboard. Wetting down may be accomplished by activating the washdown system and by using fire hoses and the fire monitors.

The washdown system is much more effective as a preventive measure than as a decontamination measure. Even if the washdown system is used only periodically to wet down the ship and is then turned off to allow normal ship operations, the washdown is more effective than it would be if contamination had fallen on completely dry decks.

NBC agent particles which impact on dry surfaces of the ship are not easily or completely removed by post-attack washdown. Prompt use of the wash-down system after NBC attack can remove more agent than if the treatment is delayed. Without wetting down prior to NBC attack, use of the washdown and/or general fire hosing will be needed as an additional countermeasure.

In areas where the runoff water flows very slowly, or collects in pools, some of the agent may adhere to the ship and, in case of chemical agents, be absorbed by paint. When the tactical situation permits, steaming on a zig-zag course helps to clear the ship of pools of water as the ship heels and, in addition, improves the distribution of the washdown spray by varying the direction of the relative wind.

Section XI. FIRE FIGHTING EQUIPMENT

6-22. EQUIPMENT. Firefighting equipment is stored at various locations throughout the vessel. Types of equipment and locations are listed below:

- a. Ten pound, Type A-II dry chemical fire extinguishers:
 - (1) 01 Level, Port Passageway, outside 3 man Stateroom.
 - (2) Main Deck, Starboard side, outside Recreation Room.
 - (3) Provisions Storeroom, by door leading to Weather Deck.
- b. Ten pound, Type B-II dry chemical fire extinguishers:
 - (1) Paint Locker, by door.

- (2) Bowthruster Room, by door.
 - (3) Main Deck, Starboard Passageway, by Machinery Space door.
 - (4) Tunnel, Forward bulkhead by Fire Station #9.
 - (5) Machinery Space, centerline on fwd bulkhead by tunnel door.
 - (6) Beside Port main engine.
 - (7) Beside Starboard main engine.
 - (8) Machinery Space, outside Machine Shop.
- c. Ten pound, Type C-II dry chemical fire extinguishers:
- (1) Pilothouse, Port side by door.
 - (2) Galley, by door.
 - (3) Emergency Generator Room, Aft bulkhead.
 - (4) Machinery Control Room, by door.
- d. There is one extra 10 pound dry chemical fire extinguisher kept onboard to be used as a spare.
- e. Fire axes:
- (1) 02 Level, port side by Fire Station #8.
 - (2) Main Deck, outside Paint Locker, by Fire Station #6.
 - (3) Main Deck, Starboard side, Weather Deck, beside Fire Station #3 (at Frame 36).
 - (4) Machinery Space, Room, Fwd of Port engine, beside Fire Station #1.
- f. Fireman's outfits:
- (1) Forward Damage Control Locker.
 - (2) Aft Damage Control Locker.
 - (3) Bowthruster Tunnel.
 - (4) Paint Locker.
- g. Oxygen Breathing Apparatus (OBAs):
- (1) Forward Damage Control Locker.
 - (2) 01 Level, Aft Damage Control Locker.

- h. Nuclear, Biological, and Chemical (NBC) equipment and gear is stored in the Arms Control Room.

6-23. FIREFIGHTING CONTROL STATIONS. In the event of a major leak or fire in the machinery space, the machinery space HALON release, machinery space ventilation, and fuel pump shut down may be controlled from the Firefighting Control Station located on the Main Deck, Starboard Passageway about Frame 38.

Section XII. HALON SYSTEMS

6-24. GENERAL. HALON 1301 Fire Extinguishing systems are provided for the Machinery Space and the Paint Locker. Upon activation, ventilation is automatically shut down so HALON will not be extracted from the space. There is a 60-second delay before the HALON is actually released to facilitate evacuation of the space.

a. Paint locker system. HALON can be released into the Paint Locker BY pulling the CO₂ lever on the CO₂ cylinder (which is located under the stairs just outside the Paint Locker door), or from the remote pull box location (which is on the bulkhead just starboard of fire station number 5 about Frame 12) by pulling the handles in both boxes. The paint locker system consists of a 72-pound cylinder filled with 64 pounds of HALON and charged by a 50-pound CO₂ cylinder. Both of these cylinders are located under the ladder just outside the Paint Locker door. There is also a single pressure operated siren which will sound upon activation to alert personnel to evacuate the space.

b. Machinery space system. HALON can be released into the Machinery Spaces by pulling the CO₂ lever on the CO₂ cylinder (located on the forward bulkhead of the Emergency Generator Room about Frame 43) or remotely at either of the two pull box locations (one on the Main Deck, starboard companion way and one on the Main Deck, forward bulkhead of the superstructure) by pulling the handles in both pull boxes.

The Machinery Space System consists of two 340-pound cylinders, each filled with 280 pounds of HALON and charged by single 50-pound CO₂ cylinder. All of these cylinders are located on the forward most bulkhead of the Emergency Generator Room. There are also two pressure operated sirens (one in the Control Room and one in the Machinery Space) which will sound upon activation to alert personnel to evacuate the space.

Section XIII. FIRE PROTECTION SYSTEM

6-25. EQUIPMENT. Fire protection equipment, heat detectors, manual fire alarm stations and associated warning bells, horns and alarms are located in various locations throughout the vessel. An alarm panel, located in Damage Control Central, in the Pilothouse, monitors six subdivisions or zones. Power for the main panel (24 VDC) is normally supplied through the emergency switchboard 24 VDC distribution.

a. Fire monitoring zones. The six fire zones are located as follows:

Zone	1	Main and Second Decks (Forward)
Zone	2	Second Deck (Amidship)
Zone	3	Second Deck (Aft)
Zone	4	Main Deck (Aft)
Zone	5	01 Level
Zone	6	Pilothouse

b. Alarm panel. The alarm panel in Damage Control Central contains modules which give visible display, by zone, of alarm conditions. In addition to an LED display, an alarm bell sounds to alert the watchstanders to abnormal conditions.

c. Thermal detectors. There are 31 thermal detectors installed on the LCU. Three of these are 140° sensors and 22 are 160° and six are 225° sensors.

d. Sensor distribution. The following list describes the units installed on the LCU, by zone and location:

Zone 1

<u>Location</u>	<u>Temperature Setting</u>
Bowthruster Room, Second Deck	225°F
Paint Locker (Main Deck)	140°F
Boatswain's Storeroom	160°F

Zone 2

<u>Location</u>	<u>Temperature Setting</u>
Engineering Storeroom	160°F
Machine Shop	160°F
Tunnel (Frame 23)	160°F
Tunnel (Frame 19)	160°F

Zone 3

<u>Location</u>	<u>Temperature Setting</u>
Machinery Space Control Station	160°F
Machinery Space (Starboard)	225°F
Machinery Space (Centerline)	225°F
Machinery Space (Port)	225°F

Zone 4

<u>Location</u>	<u>Temperature Setting</u>
Arms Control Room	140°F
Sickbay	160°F
Recreation Room	160°F
Crew's Mess	160°F

Zone 4 (Continued)

<u>Location</u>	<u>Temperature Setting</u>
Galley	160°F (2)
Provisions Storeroom	160°F
Emergency Generator Room	225°F (2)
Steering Gear Room	160°F

Zone 5

<u>Location</u>	<u>Temperature Setting</u>
Laundry Room	160°F
Crew Stateroom	160°F
Crew Stateroom	160°F
Crew Stateroom	160°F
Crew Stateroom	160°F
Engineer's Stateroom	160°F
Master' s Stateroom	160°F

Zone 6

<u>Location</u>	<u>Temperature Setting</u>
Pilothouse	160°F
Pilothouse	160°F
Pyro Locker	140° F

e. Manual fire alarm stations. There are 12 manual fire stations installed on the LCU. These manually operated "pull down" lever units allow the reporting of a fire from various locations on the vessel. The action of the lever closes a normally open contact which will activate a 10-inch bell in the Pilothouse.

<u>No.</u>	<u>Location</u>
1	Pilothouse (Starboard)
2	01 Level (Starboard Passageway), Frame 47 (outside Laundry Room)
3	01 Level (Starboard Passageway), Frame 39
4	Main Deck (Starboard Passageway), Frame 38
5	Provisions Storeroom
6	Emergency Generator Room
7	Frame 34 (Starboard), outside Recreation Room
8	Galley
9	Bowthruster Room
10	Tunnel (Centerline), Frame 25
11	Steering Gear Room
12	Machinery Space

Section XIV. SMOKE CLEARANCE

6-26. INTRODUCTION. As smoke is secondary in nature to fire, it should be considered by the firefighter in combating the fire. The primary objective must be to extinguish the fire and when that has been accomplished completely, then steps should be taken to remove the smoke and fumes that remain. Although smoke and fumes must be considered hazardous to the breathing of personnel, the hazard can be completely avoided by the use of oxygen-breathing apparatus. The reduction in visibility by smoke is a hazard as well as an annoyance which must be endured until the fire has been completely extinguished.

This procedure differs radically from that practiced ashore where ventilation is used to rid a building of accumulated heat and smoke, making access easier for rescue and firefighting. Since a single ventilation system aboard ship frequently serves a number of compartments, premature use might result in spreading a fire beyond established boundaries. This is further discussed in the following paragraphs.

Fire that occurs in the open on weather decks does not present such a serious smoke problem, as this type of fire can normally be combated from the windward side, the smoke being carried away by air currents. The problems confronted by the firefighter in combating a fire in a below-deck space are more difficult because of the presence of smoke and fumes. The firefighter's objective must be to extinguish the fire despite other difficulties.

Generally, there are no effective means for combating smoke or fumes during the progress of an interior fire. In most instances, ventilation should not be attempted during the progress of a fire in an effort to improve visibility. The known additional fire hazard resulting from the use of ventilating systems or ducts during a fire is considered of greater importance than the doubtful improvement in visibility resulting from their use. To conform with firefighting procedure as explained in this chapter, all ventilating system closures, both supply and exhaust, are secured in the area where a fire exists. Not only should ventilating system closures be secured, but electrical systems to blowers and similar devices should be deenergized also.

Open ventilating ducts, particularly in vertical systems, will act as vents for the fire, thereby prolonging the life of the fire and contributing to the difficulty of bringing the fire under control. In addition to the introduction of air (oxygen) to the existing fire, there is always the hazard of spreading the fire by combustion of dust and other debris which collects in ventilating systems as the result of infrequent or improper cleaning.

Ventilating ducts which remain open to a compartment in which there is a fire can quite easily become the vehicle for spreading fire and fumes to areas of the ship which otherwise would be unaffected. Combustible gasses or fumes passing a sparking motor may easily explode, causing further damage and possibly additional fires. The foregoing is particularly true when the access to the compartment has been opened for the purpose of fighting the fire. The open access in combination with an open ventilating duct will cause a natural draft. Ventilating system closures are provided and fitted to assist in preventing the spread of smoke and fumes to other parts of the ship as well as for preservation of watertight integrity and reserve buoyancy.

Section XV. PRECAUTIONS IN VENTILATING

6-27. PRECAUTIONS. When it has been definitely determined that the fire has been completely extinguished, natural ventilation and forced ventilation, either by the installed systems or by portable ventilating fans, can be used very advantageously for clearing compartments of smoke and fumes. However, prior to the introduction of ventilation, either natural or mechanical, certain precautions must be observed:

- a. Determine that the fire has been extinguished.
- b. Investigate the ventilating systems to the affected area to make sure they are free from fire or smoldering material.
- c. Have fire parties and equipment standing by the blower and controller of the ventilating system.
- d. Have permission of the Engineering Officer to open the ventilating system closures and start the blower as required to ventilate the compartment.

Exhaust systems should be used for clearing compartments of smoke fumes resulting from fires. The use of exhaust systems will create an in draft from adjacent spaces and prevent the smoke and fumes from spreading. Supply systems, if used, normally will force smoke and fumes into adjacent spaces causing possible smoke damage and further inconvenience to personnel. Spaces directly open to weather decks can be cleared conveniently by use of supply systems.

Section XVI. USE OF PORTABLE VENTILATING BLOWERS

6-28. PORTABLE EQUIPMENT. Portable ventilating blowers are basically auxiliary equipment, and normally are not as efficient or convenient as permanent ventilating systems. However, in the presence of explosive vapors or fumes, it may be unsafe to use the permanent systems, and only portable ventilating blowers equipped with explosion-proof motors can be used.

The axial-type blower is driven by an explosion-proof motor. It should be pointed out that while these motors are explosion-proof when assembled BY the factory, the explosion-proof quality is not necessarily present after overhaul; and where there is a possibility of explosive vapors being present, the air turbine blower should be used in lieu of the electric-driven blower with an overhauled motor.

CHAPTER 7

SHORING

SDC FIXES SHALL BE USED ONLY IN COMBAT OR OTHER EMERGENCY CONDITIONS AT THE DISCRETION OF THE VESSEL MASTER. DAMAGE SHALL BE REPAIRED BY STANDARD MAINTENANCE PROCEDURES AS SOON AS PRACTICABLE.

Section I. SHORING - INTRODUCTION

7-1. GENERAL. Shoring is the process of placing supports against the side of, below, or above a structure to prevent metal fatigue, sagging, and bulging.

Shoring is often used to support ruptured decks, strengthen weakened bulkheads and decks, build up temporary decks and bulkheads against the sea, support hatches and doors, and provide support for equipment which has broken loose.

Section II. CONSIDERATIONS FOR THE USE OF SHORING

7-2. FACTORS OF CONSIDERATION. There are three factors to be considered in regard to the use of shoring.

The first factor deals with the arbitrary limitation of pressures in the Schedule of Watertight Integrity Tests and Inspections. The maximum pressure specified in these schedules has no relationship to the strength of the structure as built into the ship. The limitation of pressure is to prevent unsightly deformation of structure during peacetime and to provide only sufficient pressure to insure a reasonable test of the space. Deformation which results from increased pressures incident to damage is acceptable, and it should be recognized that in most cases of flooding due to damage some deformation will occur.

The second factor deals with the strength of the structure in its relationship to the pressure that will be exerted on the bulkhead or deck due to actual flooding. All principal transverse and longitudinal structural bulkheads and all watertight decks are designed and built to stand the maximum static pressure which any conceivable flooding can place on these structures. Provided the bulkhead or deck is in a proper state of preservation, this pressure may result in deformation but there will be no serious threat of failure. Failure of a bulkhead may occur, however, from one of the following causes:

- a. If the structure is old, it may have been subjected to considerable corrosion and so be weakened.

b. The damage itself may cause some local weakening of the structure; this is particularly liable to occur for those structures close to an explosion.

c. The static pressure due to flooding may be increased by a dynamic pressure due to the ship's movement, either by ship speed or behavior in a sea way.

Unless one or more of the above conditions exist, there should be no necessity for shoring bulkheads or decks. Shoring is not required as a matter of routine.

The third factor has to do with the effectiveness of the shoring itself. In cases where it is necessary, the extent of shoring sufficient to be of any value will be such that the operation will be a major one. Shoring cannot be effectively provided in a period of a few minutes or even in an hour. Two or three shores placed at random will be of no value whatever. Effective shoring will consist of a reasonable complete network of reinforcement.

It is apparent that no hard and fast rules can be given as to when shoring is necessary, nor can any set methods of shoring be established in advance.

Whether or not shoring is required is a matter of judgment, with consideration being given to the known state or preservation of the bulkhead before the damage, the probability of its having been weakened by the explosion, the load on the bulkhead as evidenced by its appearance and action, and existing or probable dynamic forces working on the critical area. For riveted bulkheads, it should be safe to assume that until considerable leakage occurs around rivets or through seams, the bulkhead needs no shoring.

Section III. METHODS OF SHORING

7-3. METHODS. The methods and extent of shoring are likewise matters of judgment. The following principles, however, should be followed:

a. Bulkheads should be shored to decks either through obstructions on the decks, such as stanchions, hatch coamings, etc., or through the beams overhead.

b. Pressures should be distributed over as wide an area as possible to avoid local failure.

c. Every effort should be made to avoid damaging the caulking around bulkheads.

d. In wedging up, sufficient pressure should be exerted to relieve the load on the bulkhead, but care should be taken that flanges of bulkhead stiffeners, deck beams, etc., are not caused to buckle from excessive pressure.

Where necessary, decks may be shored to decks overhead. The shoring should extend to headers on the deck and under the overhead deck beams so

arranged as to distribute the load over a large area or to carry it to some point of local strength, such as bulkhead overhead. The same procedure should be followed in shoring one bulkhead to another.

In common with other features of damage control, the possible necessity for shoring bulkheads must be recognized, and general provision for accomplishing this operation must be made beforehand. The actual operation should, however, be governed by conditions which exist when and if shoring is found necessary.

It should be noted that all effective members, except those used to distribute pressure over wide areas, are direct compression members. The material at hand, assumed to be wood, should be arranged so that the length of direct compression members is not more than 30 times the minimum thickness or diameter and preferably not more than 15 times. Thus a 4" x 4" timber could be 10 feet long, but, were it only 5 feet long it could take a 50 percent greater load.

For shoring, which is a temporary emergency expedient, materials may be stressed almost to the breaking point. Having determined the necessity for shoring, and the type and arrangement, the extent of shoring is largely a question of trial and error; in other words, add more shores until the bulkhead is held securely.

Although the discussion above refers particularly to shoring bulkheads, it applies also to shoring decks.

Section IV. MATERIALS FOR SHORING

7-4. SHORING MATERIALS. The basic materials required are shores, wedges, holes, and strong backs. A shore is a portable beam. A wedge is a block which is triangular on the sides and rectangular on the butt end. A shole is a flat block which can be placed under the end of a shore to distribute the pressure. A strong back is a bar or beam of wood or metal, often shorter than a shore, which is used to distribute pressure or to serve as an anchor for a patch. Lumber to be used for shoring is stored in the bow thruster tunnel dam- age control lumber rack.

7-5. TOOLS AND EQUIPMENT. Many items of tools and equipment are used when shoring. These include wooden battens, claw hammers, mauls and sledges, hand- saws, mattresses and pillows, axes and hatchets, wood clamps, chainfalls, electric welding machines, oxyacetylene cutting outfits, cold chisels, wood chisels, nails, wooden plugs, packing sheets, turnbuckles, screw jacks, hydraulic jacks, bolts, nuts, and washers.

7-6. PROPER WOOD FOR SHORING. The best woods available for shores are Douglas fir and yellow pine. Hemlock and Spruce can be used, but they are not as strong. The wood used for shores should be straight grained and relatively free from knots and cracks. Shores could be treated with a fire-resisting chemical and should never be painted.

Section V. PREPARING SHORING MATERIAL

7-7. LENGTH OF A SHORE. In use, the length of a shore should never be more than 30 times its minimum thickness; therefore, a shore that is 4 by 6 inches should not be longer than 10 feet. The shorter the shore is in relation to its thickness, the greater the weight it will support.

7-8. MEASURING AND CUTTING SHORES USING A BATTEN. The most rapid and accurate way to measure shores for cutting is by using an adjustable shoring batten. An adjustable shoring batten, such as the one shown in FIGURE 7-1 can be made from materials aboard the vessel. To use the shoring batten, extend it to the required length and lock it with the thumbscrews on the length locking device. Measure the angles of cut by adjusting the hinged metal pieces at the ends of the batten, and lock the angle locking device in place. Lay the batten along the shore, and mark and cut the timber to the proper length and angle. Shores should be cut 1/2 inch shorter than the measured length to allow space for wedges.

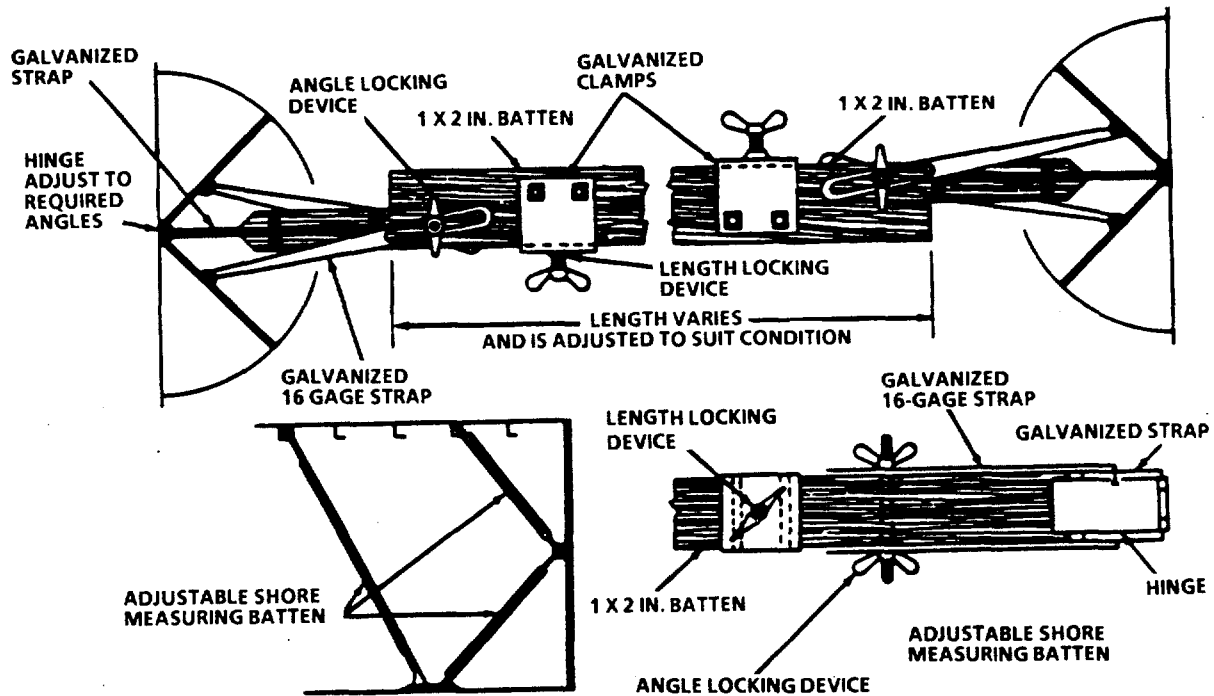
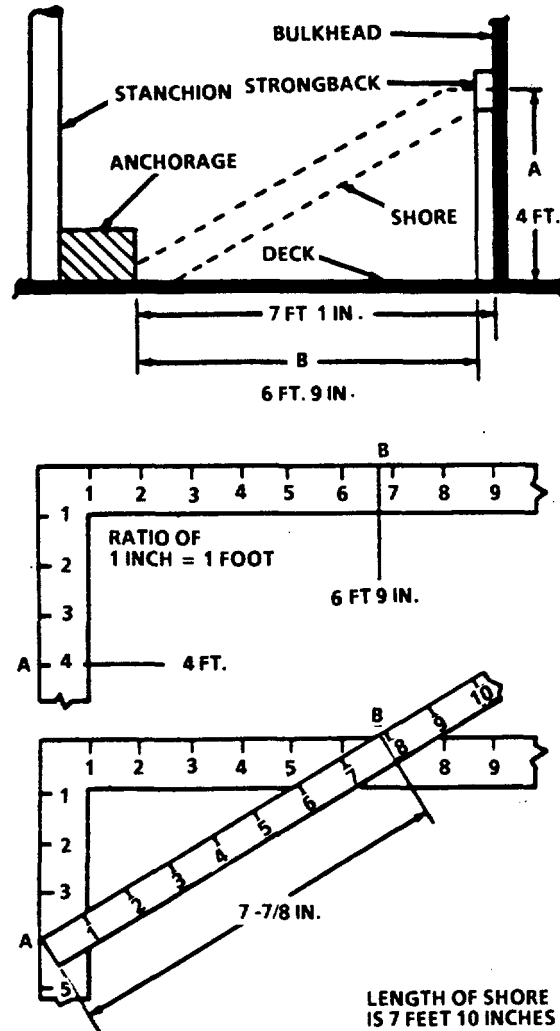

FIGURE 7-1. Adjustable Shoring Batten.

7-9. MEASURING AND CUTTING SHORES WITHOUT A BATTEN. If a shoring batten is not available, measure the shores for length by using a folding rule or a steel tape and a carpenter's square, as follows:

- a. Measure distance A (FIGURE 7-2) from center of strong back to deck. Then, measure distance B from edge of anchorage to bulkhead, subtracting thickness of strong back.



PED/SDC-17

FIGURE 7-2. Determining Length of Shore.

b. Lay off, on a carpenter's square, measurements A and B, using ratio of 1 inch to 1 foot.

c. Measure the diagonal distance between A and B. In the example given in FIGURE 7-2, this distance is 7-7/8 inches. The distance in feet would be 7-7/8 feet, or 7 feet 10-1/2 inches. Subtracting 1/2 inch for wedge space, the required length of the shore is then 7 feet 10 inches.

Section VI. APPLICATION OF SHORING

7-10. TRIMMING AND FITTING SHORES. Shores must be trimmed to fit the shoring structure, and the trimming must be done in such a way as to prevent splitting or chipping of the shores. If shore A in FIGURE 7-3 is to fit against a plane surface of shore B, and if it must take a load in compression, the end of shore A must be cut square and perpendicular to the long axis of shore A. Sharp points must never be used when shoring is required to withstand pressure. FIGURE 7-4 shows the correct way to fit shores to present a flat surface at each pressure area. The carpenter's square can be used to measure the angles of cut and to mark the shore for cutting. Shores are sometimes

notched at the end to fit against other shores, but this method should not be used if any great pressure is to be expected. A safer method is to cut a socket in the side of one shore and fit the butt of the other shore into the socket. This method is shown in FIGURE 7-5.

7-11. **SHORING BULKHEADS.** Most shoring of bulkheads is done to support bulkheads which are endangered by structural damage or weakness caused by the pressure of flooding water. Methods of shoring bulkheads are shown in FIGURES 7-6, 7-7, and 7-8. Observe the following when shoring bulkheads:

- a. Allow a large margin of safety in number of shores used.
- b. Spread pressure. Make full use of strength members by anchoring shores against beams, stringers, frames, stiffeners, and stanchions. Place legs of shoring against strongback at an angle of 45 degrees or 90 degrees if at all possible.
- c. Do not attempt to force a warped, sprung, or bulged bulkhead back into place. Place shoring so that it will hold bulkhead in its warped or bulged position.
- d. Strengthen main shores, when possible, with auxiliary shores, as shown in FIGURE 7-8. Notice that strength members A, B, C, and D have been locked in place with auxiliary shores E and F to keep them from jumping out as the ship works in the seaway. Cleats H and J hold E in place.

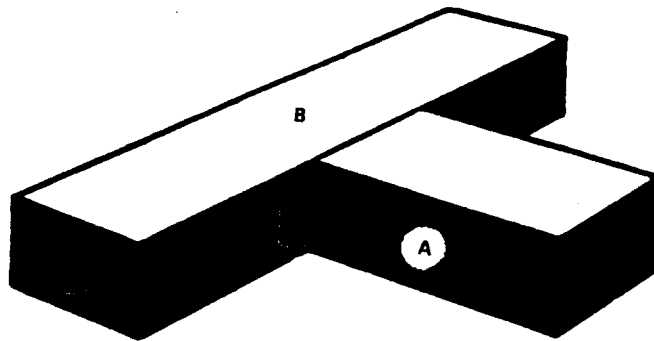
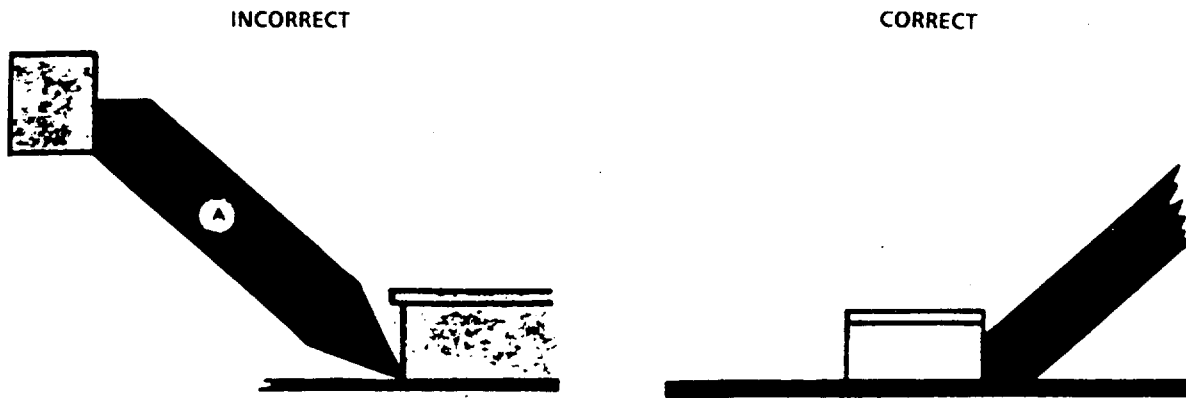

FIGURE 7-3. Fitting Shores Together.



PED/SDC-19

FIGURE 7-4. Cutting the End of a Shore.

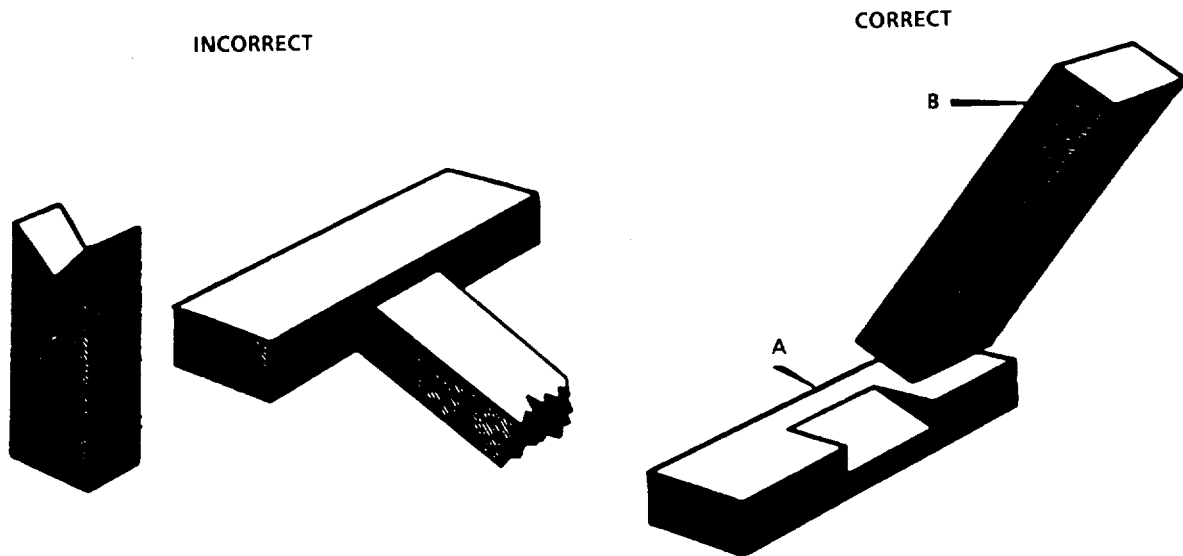

FIGURE 7-5. Notching a Shore to Fit Another.

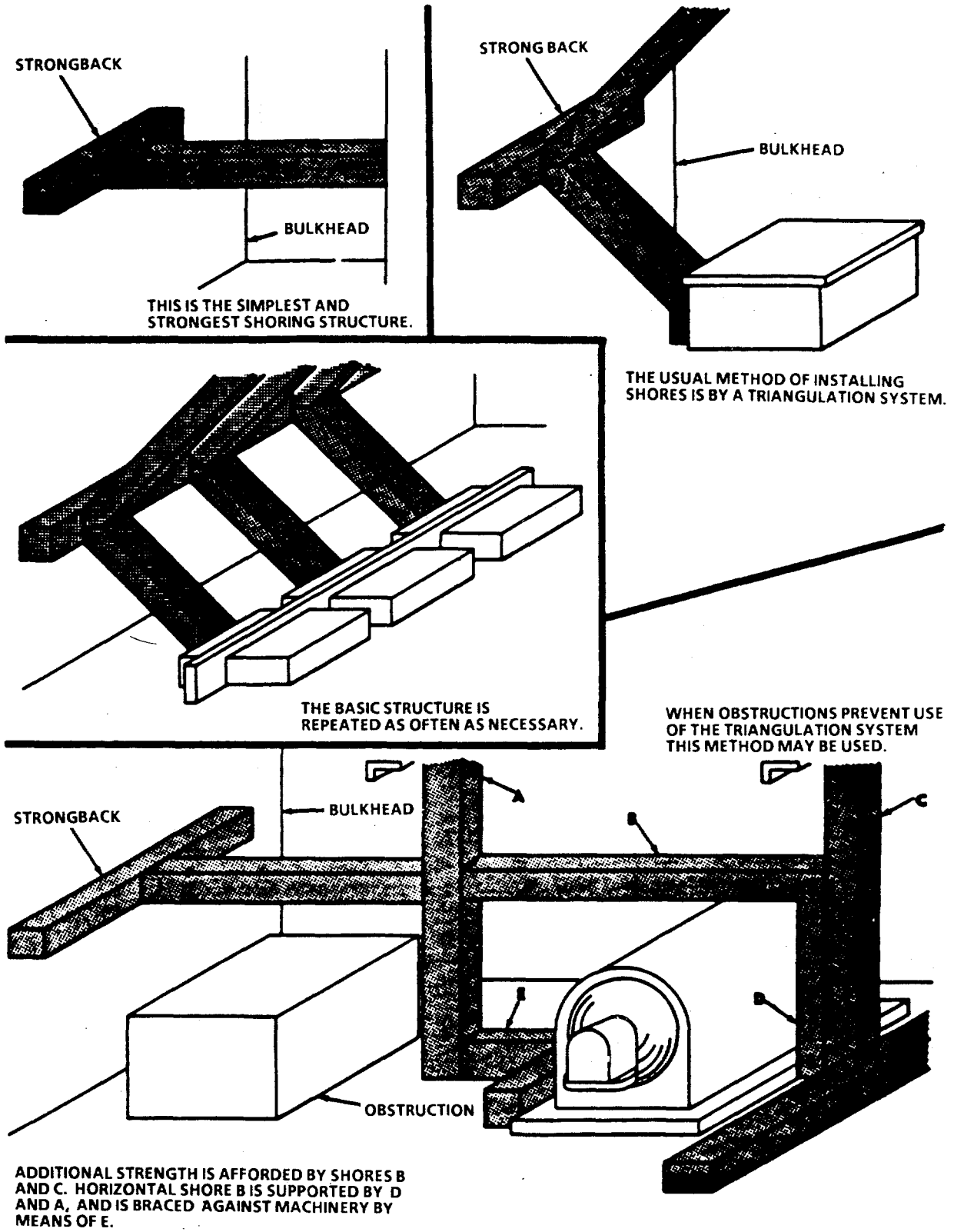
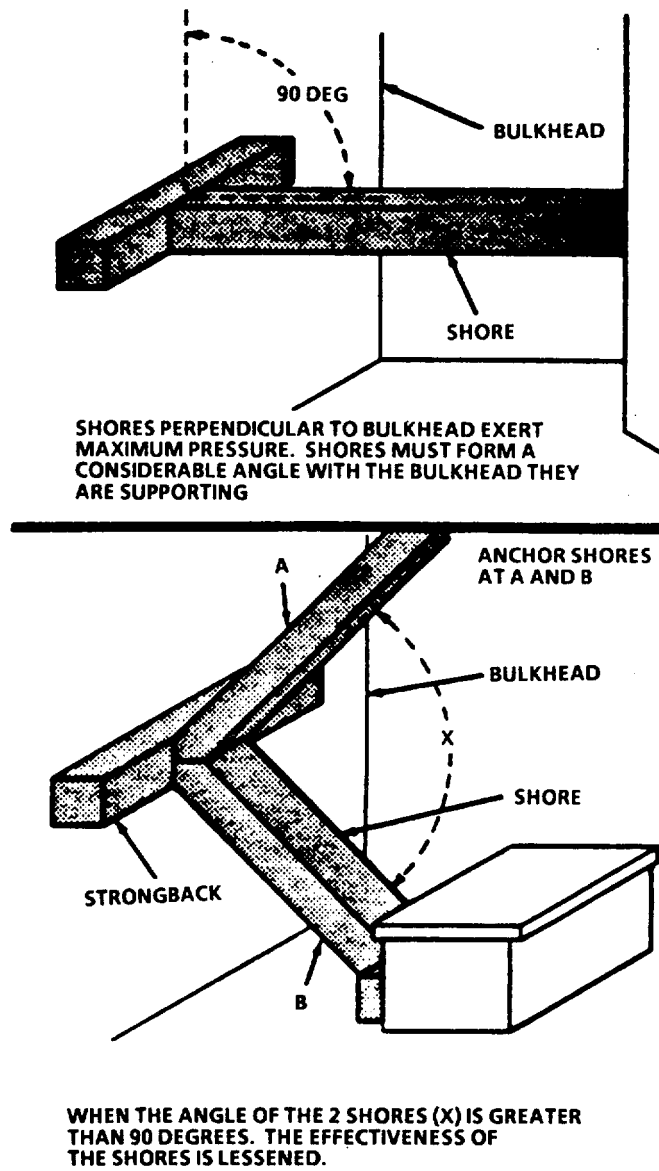
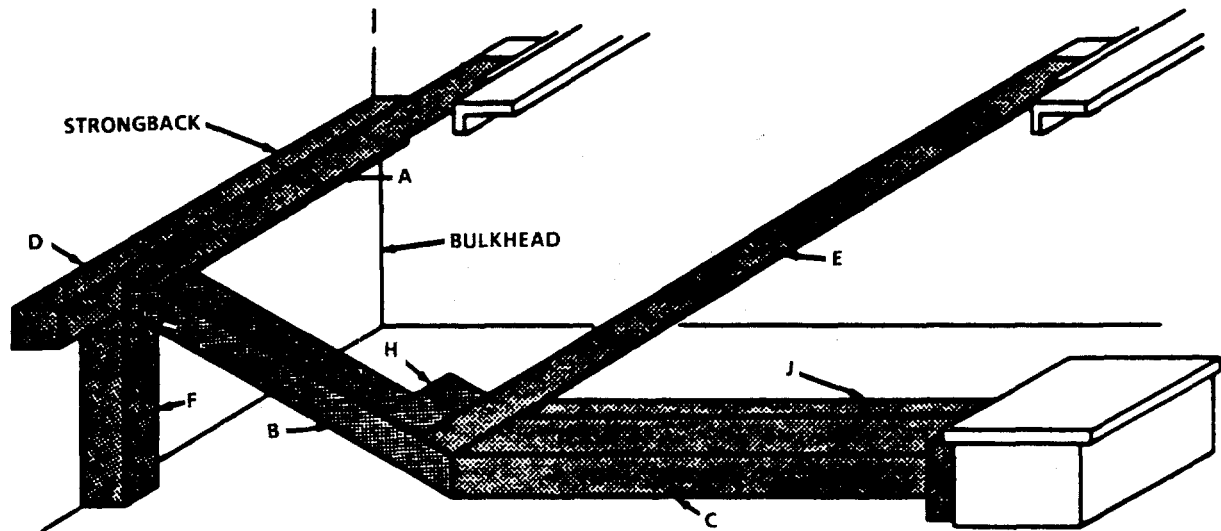

FIGURE 7-6. Shoring Against Horizontal Pressure.



PED/SDC-22

FIGURE 7-7. Correct Shoring Angles.



THE STRENGTH MEMBERS A, B, C, D, HAVE BEEN LOCKED IN PLACE WITH AUXILIARY SHORES E AND F TO KEEP THEM FROM JUMPING OUT AS THE VESSEL WORKS. CLEATS H AND J HOLD E IN PLACE.

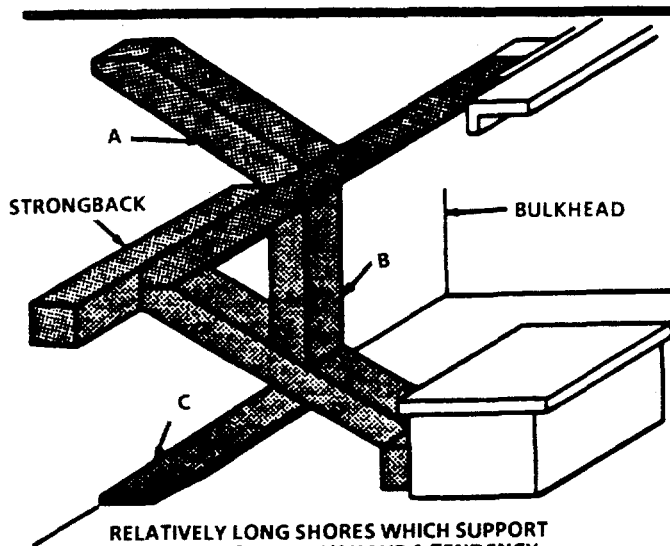

RELATIVELY LONG SHORES WHICH SUPPORT HEAVY PRESSURE, MAY HAVE A TENDENCY TO BOW. SUPPORTING SHORES A, B, C SHOULD BE INSTALLED FOR GREATER THE STRENGTH.

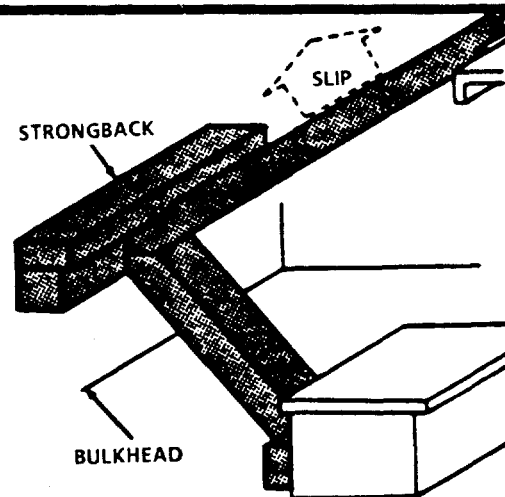

WHEN ONE SHORE IS LONGER THAN THE OTHER, A WIDER STRONGBACK WILL KEEP THE LONGER ONE FROM SLIPPING.

PED/SDC-23

FIGURE 7-8. Strengthening Shores.

7-12. SHORING HATCHES OR DOORS. The general principles of shoring bulkheads described above apply to shoring a hatch or a door. The entire hatch or door should be shored and the pressure should be spread over both the hatch cover or door and the supporting structure, as shown in FIGURE 7-9. Hatches and doors are the weakest part of the bulkhead or deck in which they are installed.

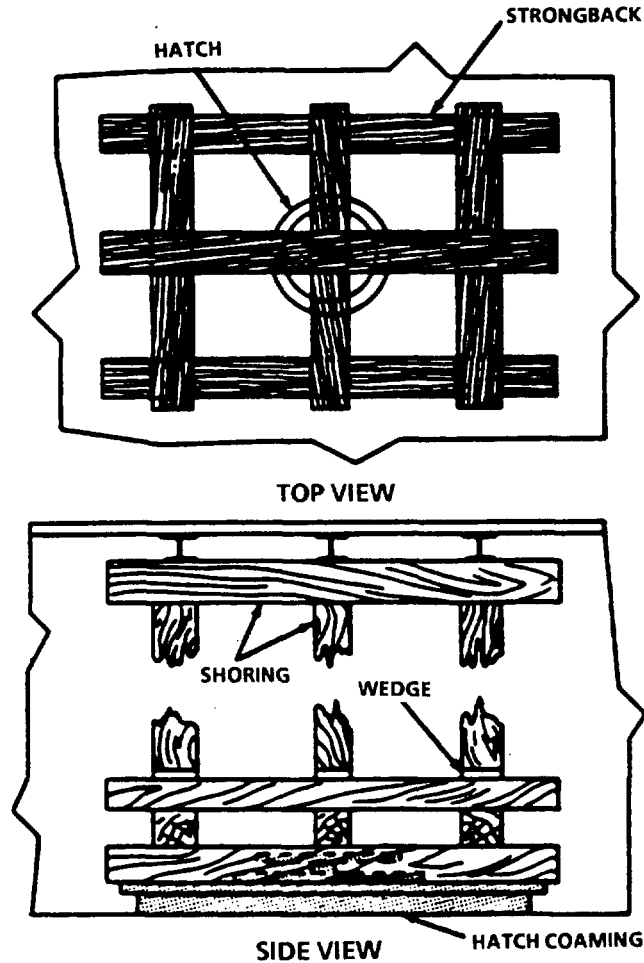

PED/SDC-24

FIGURE 7-9. Shoring a Hatch

7-13. STRONGBACKS. All or part of an ordinary shore can be used to make a strongback. Shoring scraps should be kept for use as strongbacks and short shores. Heavy planks, steel bars, angle irons, and pipe can also be used as strongbacks.

7-14. WEDGES. As the shoring job progresses, check carefully to see that all wedges are exerting about the same amount of pressure on the member being shored (FIGURE 7-10). Use as few wedges as possible to obtain satisfactory results. Wedges are usually made of soft wood, preferably fir or yellow pine. A few hardwood wedges should be kept on hand for special use where resistance to crushing is required. When hardwood wedges are used, they must be checked frequently, as they have a tendency to work loose. Wedges should be approximately as wide as the shores with which they are used. They should be cut with a coarse saw and left unpainted to absorb water and hold better. They can be made with various angles at the leading edge. Blunt wedges do not hold as well as sharp ones. A wedge should be about six times as long as it is thick. Thus, a wedge to be used with a shore that is 4 by 4 inches should be about 4 inches wide, 2 inches thick, and 12 inches long. Always drive wedges uniformly from both sides so the shore end will not be forced out of position. Lock wedges in place so that they will not work loose and cause the shoring to slip (FIGURE 7-11).

7-15. USE OF SHOLES. Sholes (FIGURE 7-12) should be made of Douglas fir or yellow pine planks 1 inch or more in thickness and from 8 to 12 inches wide. Wider sholes can be made by nailing cleats across two or more widths of planking. Single planks can be cleated at the ends to keep them from splitting.

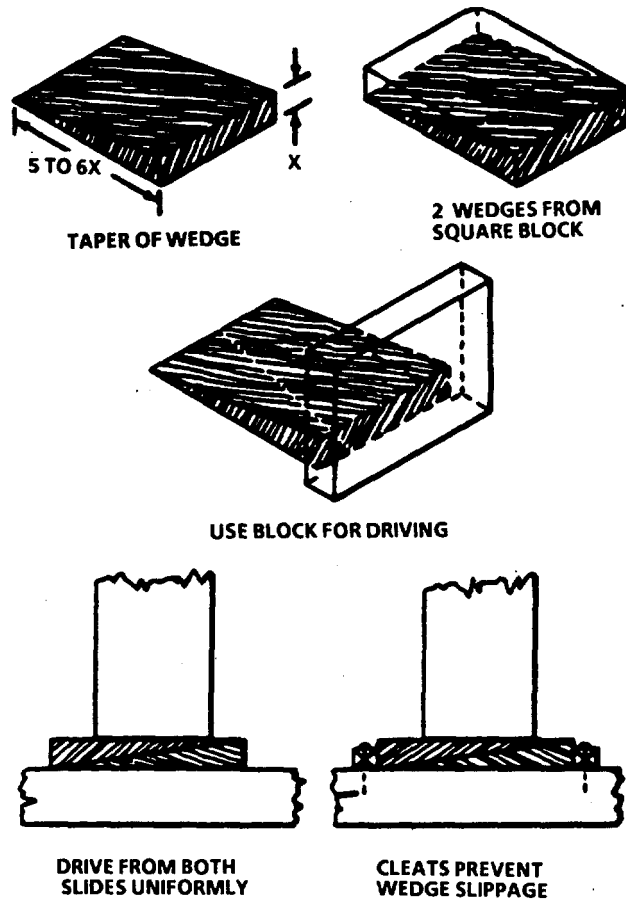

PED/SDC-25

FIGURE 7-10. Use of Wedges in Shoring.

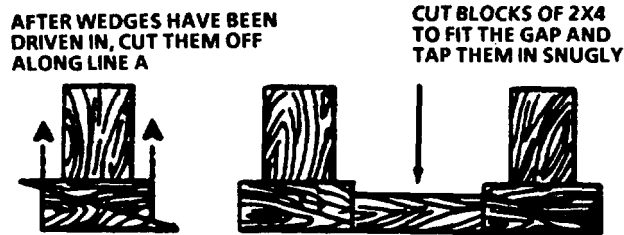

PED/SDC-26

FIGURE 7-11. Locking Wedges in Place.

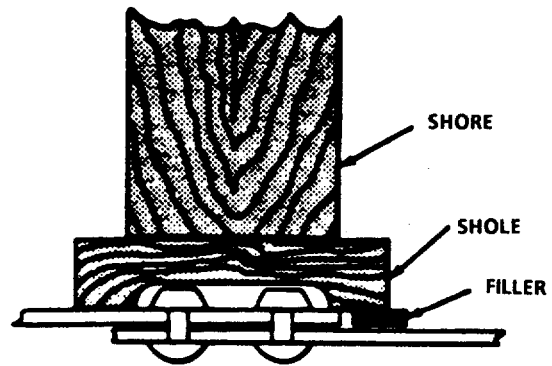

FIGURE 7-12. Use of a Shole.

CHAPTER 8

FLOODING

SDC FIXES SHALL BE USED ONLY IN COMBAT OR OTHER EMERGENCY CONDITIONS AT THE DISCRETION OF THE VESSEL MASTER. DAMAGE SHALL BE REPAIRED BY STANDARD MAINTENANCE PROCEDURES AS SOON AS PRACTICABLE.

Section I. FLOODING LOAD

8-1. GENERAL. Seawater weighs approximately 64 pounds per cubic foot. Therefore, the pressure over 1 square inch at a depth of 1 foot is 0.444 pounds; at 9 feet, it is 3.9996 pounds; at 20 feet it is 8.88 pounds. The pressure at any point is equal in all directions, whether downward toward the deck or horizontally toward a bulkhead. A bulkhead 20 feet wide and flooded to a depth of 5 feet would be subjected to a total pressure of 16,000 pounds. $P = 1/2 (64) (20) (5^2)$. At 8 feet high and 20 feet wide and flooded to a depth of 15 feet over the deck, a bulkhead would have a total pressure of 112,640 pounds on it. This will give some idea of the pressures that must be contained. If the ship remained entirely motionless in all three planes, the pressure at any given point would remain constant and the problem of shoring would be relatively simple. It would be possible to erect a light shoring structure, and then leave it without further inspection. It may not be necessary to shore.

a. Flooding load-sagging. The load on the ship's girder is increased by the presence of flooding water. The increase in stress caused by this augmented load depends on both the amount and location of the flooding. Damage and consequent flooding in the middle length increases sagging stresses. This increases the tension at the bottom and compression at the top of the hull girder. Measures to correct trim caused by damage in the middle length should be aimed to reduce sagging stresses. This may be accomplished by one or all of three methods:

- (1) Pump liquid in the midships region overboard (either flooding water or liquid in intact tanks-consider stability before pumping low weights overboard).
- (2) Transfer liquids from midships region to ends.
- (3) Counterflood high end (assuming good freeboard).

b. Flooding load-hogging. Flooding at the ends produces trim and increased hogging stresses. This will increase tension at the top and compression at the bottom. In this condition, measures for the correction of trim to reduce hogging stresses are:

- (1) Transfer liquids toward midships.
- (2) Pump liquid near damaged overboard (flooding water or liquid in intact tanks-consider stability before pumping low weights overboard).

(3) Flood midships tanks (assuming good freeboard).

c. Counterflooding. At times, counterflooding may be required to halt listing or gain safe righting moments. However, counter-flooding can be dangerous and result in loss of a ship if not properly accomplished and controlled. A recommendation by the engineer to counterflood shall be accomplished only with the approval of the vessel master, and only when all aspects have been carefully considered.

d. Flooding boundary. A flooding boundary is established by locating the bulkheads and decks which are dry and likely to remain dry. The next action is to advance that flooding boundary toward the original point of damage by preventing further flooding of dry or partially-flooded compartments. It is important to close in on the damage from all sides. Even though a flooding boundary has been established, there is no indication that the boundary will remain safe. Action must be taken by the repair party to advance that flooding back toward the point where the damage occurred.

Many ships have been lost as a result of naval action. Few of them sank as a direct result of the initial damage; most of them went down hours later as a result of progressive flooding, fire, collapsing bulkheads, increased free-surface, and human errors. Had flooding and fire boundaries been established when and where they were possible and had the damage been confined to its original area, even though that area was large, many of those ships would have survived.

Do everything to prevent the flooding and burning from advancing. It is human weakness to attack obvious damage while ignoring hidden damage that may sink the ship. Hours often are wasted by repair teams who are trying to patch large or multiple holes in compartments which are already flooded or have large free-surface areas. Smaller holes through interior bulkheads, holes that are allowing progressive flooding and more free-surface, often are overlooked. In most cases it would be better to plug interior holes first in order to hold what you have.

Section II. INVESTIGATING FLOODING DAMAGE

8-2. INSPECTION. Inspect thoroughly. When an underwater explosion occurs alongside or close aboard, all voids, tanks, and lower compartments on the ship must be investigated. Rivets or plating may be torn loose, plating may be cracked, seams may be parted, and bulkheads and shell plating may be penetrated. This damage could occur a considerable distance from the principal point of damage.

Furthermore, internal flooding may spread over a large area through watertight fittings damaged by shock, or through neglected watertight fittings.

Not all of these secondary casualties will be apparent during a preliminary investigation. If water is on the opposite side of a bulkhead containing cracks or defective stuffing tubes, damage readily may be detected. If flooding has not yet reached the area, however, damage may not be visible, and it may not be noticed until a degree of progressive flooding has occurred.

Inspectors and other personnel must exercise care to prevent open doors, hatches, and scuttles from being fouled in any manner that would prevent or delay their exit or their ability to resecure the opening. Should the motion of the ship cause the door or fitting to swing, personnel should be directed to tend the fitting while open and resecure when it is no longer required to open.

8-3. STRUCTURAL DAMAGE. Flooding is usually the result of structural damage below the waterline. It is vital to prevent progressive flooding, and to remove as much of the water as possible in order to restore buoyancy and stability and to return the ship to an even keel.

Investigation of structural damage must cover a considerable area surrounding the immediate scene of damage, not only on the same level but also on decks above and below the principal casualty. Investigators must look for damage such as fragment holes, ruptured pipe lines, warped or fractured frames and stanchions, cracks, open seams, leaky stuffing tubes, bent shafts, improperly closed fittings, and severed electric cables, and must note quickly any damaged bulkheads which indicate hidden damage which in itself could be as hazardous to the ship as the prime damage.

8-4. HIDDEN DAMAGE. The complete picture of a damage situation rarely is fully evident. Some damage may not necessarily be within the immediate area. Shock, blast, fragmentation and other forces cause additional damage, which, because of remoteness from the scene of the prime damage and not immediately apparent, could be overlooked during the period immediately following the initial damage. The inspection of the ship for damage, therefore, must not be focused solely upon the prime damage area. Open circuit-breakers and failure of operating gear could indicate hidden damage which in itself could be as hazardous to the ship as the prime damage.

8-5. CHECK ADJACENT COMPARTMENTS. Investigators must understand that damage to compartments adjacent to the one in which an explosion occurs is likely due to secondary penetrations and shock.

8-6. INVESTIGATION OF WATERTIGHT FITTINGS. Investigation of structural damage by visual examination presents many difficulties and dangers.

WARNING

No watertight door, hatch, air fitting, oil fitting, cap, plug, scuttle, or manhole is to be opened until it is known definitely that the compartment on the other side is either completely dry, or so little flooded that opening the closure will not permit flooding to spread. Failure to do so could cause additional flooding. Injury to personnel may result.

To do a thorough damage control investigation, it might be necessary to open one or more watertight doors or hatches. It is unwise to open any such closures below the waterline in the vicinity of damage unless this is preceded by a thorough investigation by means of soundings, and only after permission is obtained from high authority whenever the situation permits. One mistake and the ship may be lost.

No compartments are provided with sounding tubes. This is no bar to investigation, however. Tapping on a bulkhead with a hammer will often disclose the presence of water on the other side; the exact height of the water may be judged by variation in the tones produced when the bulkhead is struck at different levels. Repair team members occasionally should tap various bulkheads for practice to train their ears to the sound of bulkheads around undamaged areas. The tones will vary appreciably with the thickness of the plate.

A dangerous but often necessary method of testing a compartment for flooding is to slowly slack off on the hinged side of some of the dogs which hold a hatch or door closed. There is a slight amount of clearance around the hinge pins, and as the dogs are loosened, any water present will begin to seep between the gasket and the knife edge on the side. Control is still maintained by means of the hinges and the opposite dogs. This method cannot be used with quick-acting doors and scuttles.

Crew members must not loosen the dogs on the edge of the door away from the hinges. To do so could result in having the door buckle or fly open and another compartment would be flooded needlessly. Personnel casualty may result.

Secure every fitting after testing.

8-7. HOLES IN THE UNDERWATER HULL. As the damage investigation progresses, it may eventually come to a bulkhead that has holes in it, cracked plates or seams, warped hatches, leaky stuffing tubes, or holes made by blast or by fragments. By plugging these holes, it is possible to localize flooding and preserve buoyancy, and by the removal of water from these compartments so made tight, further action can be taken to minimize the damage.

a. Water pressure. Water pressure causes difficulties when it becomes necessary to make repairs to underwater holes although these difficulties are frequently overestimated. A hole submerged on one side only is subjected to an inward pressure of 0.444 pounds per square inch for every foot of submerged depth. A hole 7 feet below the waterline will be subjected to a pressure of 3 pounds per square inch. A circular hole 5 inches in diameter and 9 feet below the waterline will be subjected to a total pressure of 78-1/2 pounds. These pressures are not excessive and they are reduced if the hole is submerged on both sides.

b. Accessibility. The greatest difficulty in repairing underwater holes is often the lack of accessibility. If the inboard compartment is flooded, it may be dangerous to attempt any repairs because to open a hatch or a door may permit flooding in another compartment.

8-8. HOLES AT WATERLINE. Holes in the hull at or just above the waterline are dangerous because they may not appear to be of immediate consequence. They destroy reserve buoyancy and, should the ship roll in a heavy sea or lose buoyancy, the holes become submerged and admit flooding water above the center of gravity. This is dangerous because this condition reduces stability and the flooding water invariably presents a large free-surface. As this occurs, the situation becomes increasingly dangerous. These holes must be plugged at once, therefore, with priority being given to holes at the waterline on the low side.

Section III. METHODS OF REPAIRING HOLES

8-9. REPAIRS-GENERAL. There are two general methods of repairing a hole: either put something into it or put something over it. In either case, try to reduce the area through which water can enter the ship or an area through which it can pass from one compartment to another.

a. Wooden plugs. Wooden plugs provide the most simple method of repairing small holes. Plugs made of soft wood are effective under battle conditions, especially in holes not over 2 x 3 inches. They have held up well in much larger holes. Every ship should have a large assortment of conical, square-ended, and wedge-shaped wooden plugs at each repair station. The plugs should not be painted, as unpainted soft wood absorbs water and grips better. The plugs should be stowed in canvas bags secured to the overhead. Combinations of conical, square-ended and wedge-shaped plugs may be used to get better conformation with the shape of the hole. It is best to wrap the plugs with lightweight cloth before inserting. The cloth will help the plugs to grip better and will also fill some of the gaps between plugs. Wooden plugs will not always make a watertight fit, but by caulking the remaining leaky area with rags, oakum, and smaller wedges, the ingress of water can be greatly reduced. Square-ended plugs hold better than conical plugs in holes in plating 1/4 inch or less in thickness.

Most wooden plugs are inserted from inside the ship. In that case, they have to contend with metal edges protruding inward. Plugs driven in from outside may not have as much interference, but outside plugs cannot be tended readily. They are often knocked out by the action of the sea and do not hold up as well over extended periods of time.

b. Pillows and mattresses. Pillows and mattresses have been rolled up and shoved into holes. They have been rolled around a wooden plug or a timber to increase their size and to provide rigidity. Wrapping them in a blanket sometimes helps. Such plugs cannot be relied upon as they have a tendency to be torn out of the holes by the action of the sea.

c. Cloth plug. A most effective plug was made by a ship after an enemy shell had torn an 8" x 10" hole in the side at the waterline. Unable to make repairs from inside because of wreckage, the ship crew made a built-up conical plug of cloth. The core was a piece of heavy line 3 feet long. An eye was spliced into each end of this core line, which was then wrapped with strips of blanket until a cone was built up, 2 inches in diameter at one end and 2 feet in diameter at the other end. The layers of cloth were held together and to the core line by stitching. Lines were secured to the eyes in the core line, and by means of these lines the plug was lowered over the side and pulled into place. Such a plug has flexibility; it will adapt itself to irregular shapes. Furthermore, it will absorb water and swell making it more effective.

d. Plate Patches. Prefabricated patches can be made with a square piece of 10-pound (1/4-inch) steel plate. One method is to place a thick gasket near the edges. Strips of old rubber tires will do, but a far better gasket is a thick tube of canvas stuffed with oakum or cloth. It can be secured to the plate with machine screws, washers, and nuts, but the holes through the plate must be reamed so the screws will not hold the plate away from the ship. The gasket can also be

held in place with retainer strips. At the center of the inner side weld is a ring or eyebolt to secure a line which holds the patch close to the skin of the ship.

Another method often used is to drill a hole through the center of the plate and to insert a line through the hole, with the outboard end knotted. The line used may be either wire or manila. Wire is stronger and it does not give easily. When coated with fuel oil, however, wire is very slippery. Manila line is recommended. These plates are made in various sizes up to 5 feet square. The larger sizes are very heavy and it is necessary to weld an eye at the top center to secure a handling line, which also can act as the vertical support with the patch in place. Similarly, eyes may be welded in place at the forward and after ends for securing guys. This patch is lowered over the side by the handling and supporting line. A crew member inside the ship reaches out through the shell hole, grabs the center line, and pulls the patch tight against the ship's side. The center line then is made fast to a stanchion.

Every ship carries a large amount of material from which almost identical patches can be improvised, such as mattresses, pillows, blankets, mess tables, joiner doors, planks, floorplates and gratings.

e. Hinged plate patch. A variation of the plate patch is a circular plate 18 inches or less in diameter cut in two and so hinged that it may be folded and pushed through a hole from inside the ship. The plate is to be fitted with a gasket and a line for securing it to the ship. This patch is designed for use over a relatively small hole as it has no vertical support to hold it in place.

f. Flexible plate patch. A flexible variety of the plate patch has been suggested for use over curved surfaces, such as the turn of the bilge. The plate is made of lightweight sheet-metal reinforced with parallel strips of light angle iron, welded in place, about 6 or 8 inches apart. The plate is provided with four eyes for securing lines, and it should have some kind of soft gasket on the facing surface. It is, in effect, a stiff, metal collision mat.

g. Patches inside ship. Sometimes it is desirable to place the patch inside the ship, not only to make it accessible but to reduce the danger of having the patch knocked away by sea action. For inside patches, innerspring mattresses are preferred principally because they hold their shape better while being placed, are thicker, and adjust better to protruding edges. It would be well to use at least one thickness of blanket as a facing for an innerspring mattress. Two thicknesses of crew mattresses generally will be more effective than a single mattress.

The mattresses should be backed with joiner doors, steel plates, or wooden plates made of cleated planks, and they must be shored stoutly in place. Holes or cracks into which the mattress cannot be pushed may be stuffed with rags, oakum, and wedges. In some cases, these patches have not been satisfactory but they have given good results over many shell holes and in replacing damaged watertight doors.

h. Pillows, blankets, and kapok life jackets. Feather pillows do not make effective patches or gaskets over a long period of time. When the feathers get wet, they will collect in a lump at one end of the ticking cover, and the patch practically collapses. Furthermore, if the casing rips, the feathers come out and clog the pump strainers badly. Kapok life jackets are more effective. Folded blankets can be used in place of pillows.

i. Box patch. A suitable patch for use over holes having jagged edges protruding inward is a steel box running in sizes up to 18 inches square and 6 inches deep. The box is open at one end and has a gasket running along the facing edges. The gaskets may be made of rubber or of canvas stuffed with oakum. The box is put over a shell hole from inside the ship and is held in place with shoring. When the compartment is pumped dry, the box may be secured by welding angle clips between the box and the hull plating, after which the timbers can be removed for use elsewhere. The box cannot readily be fitted to uneven surfaces, so variations have to be made in its use. One variation is to stuff the box with pillows, or to lay pillows over the hole before applying the box. This has proven successful. Another variation is to stuff rags and wedges into holes between the box and the rumbled hull. In the absence of ready-made steel boxes, similar patches can be made of planks. The advantage of a wooden box is that its edges can be shaped with a hatchet to fit closer to corrugations in plating. It is suggested that large ships make and carry box patches in sizes up to 4 feet square and 1 foot deep.

j. Bucket patch. An ordinary galvanized bucket can be used in a variety of ways to stop leaks. It can be pushed into a hole, bottom first, to form a metal plug, or it can be stuffed with rags and put over a hole like the box patch previously described. It can be held in place by shoring or by using a hook bolt which will be described later.

k. Hook bolts. A hook bolt is a long bolt having the head end so shaped that the bolt can be hooked to plating through which it has been inserted. The common types are the T, the J and the L, as illustrated in FIGURE 8-1, so called because they resemble those letters. The long shanks are threaded and provided with nuts and washers. Steel or wooden strongbacks are used with them, generally the latter. The bolt has no regular head.

l. The head end of the bolt is inserted through a hole and the bolt is rotated or adjusted until it cannot be pulled back through the hole. A pad or gasket, backed by a plank or a strongback, is then slid over the bolt, and the patch is secured in place by taking up on the nut. Generally it is necessary to use these bolts in pairs. Hook bolts can be used in combination with many of the patches previously mentioned, especially the folding plate, the box, and the bucket.

m. Folding T. A variation of the hook bolt is the folding T. It resembles the T-bolt, but it has a hinge where the shank joins the crosspiece so it is much like the tumble toggle bolt. This bolt may be folded and inserted through a small hole; when pulled back, the crosspiece catches on the hull plating. By using this bolt, a crew member standing inside the ship can put on a patch either inside or outside the ship. By means of retaining line on the bolt, a strongback and a pillow can be threaded over the line and the entire patch folded and tossed out through the hole. When the line is hauled in, the patch takes up against the ship where it can be readjusted to give a tighter fit; or the pillow and plate can be pushed over the shank inside the ship, which will give an inside patch. Nuts and washers are provided for holding and

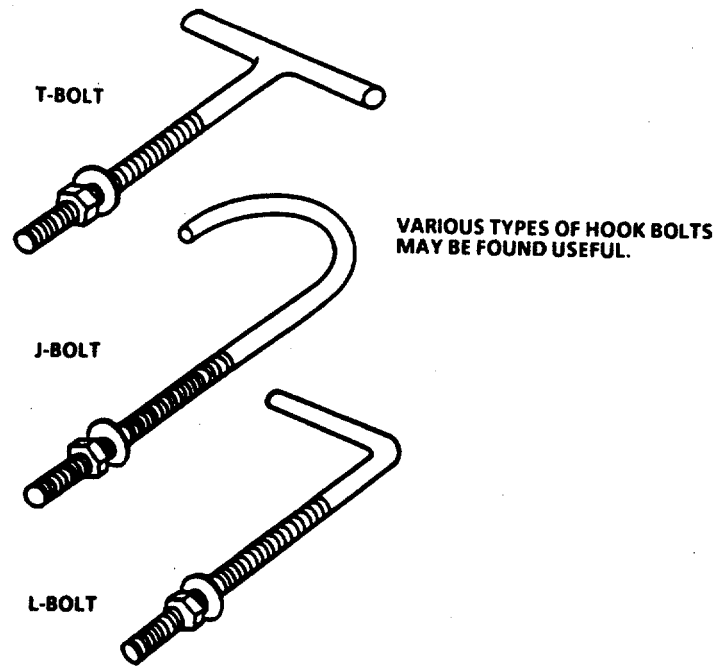

PED/SDC-28

FIGURE 8-1. Types of Hook Bolts

tightening the patch. It might be well to put large wings on the nuts.

Section IV. QUICK-SEALING LEAKS AND CRACKS

8-10. METHODS. Quick action in sealing leaks and cracks can prevent further flooding or even advance the flooding boundary back to the area of damage. The following paragraphs describe a number of methods for sealing leaks and cracks.

a. Crack in steel plate. A fairly common type of leak is caused by a crack in a steel plate. When the leak is in a flat surface away from frames and other interferences, generally it can be stopped by scraping the surface smooth and applying a patch of sheet packing backed by a shole which can be held in place with shoring.

b. Crack adjacent to frame. When the crack is adjacent to a frame, it may be necessary to use oakum held in place by the corner of a timber. Advantage should be taken of adjacent framing to use clamps for holding the stopper in place.

c. Torn plating. Upon reinspectng a crack, it may be found that it has increased in length. The plating is being torn like paper. To prevent further cracking, drill quarter-inch holes at the extreme ends of the crack, and plug the holes. If there is time, weld a plate over the crack. This technique is illustrated in FIGURE 8-2.

d. Caulking thin plating. Generally, it is not advisable to drive wedges into cracks in thin plating, especially hardwood wedges, as the wedges tend to open the cracks. Marline, oakum, and rags often can be used as effective caulking materials.

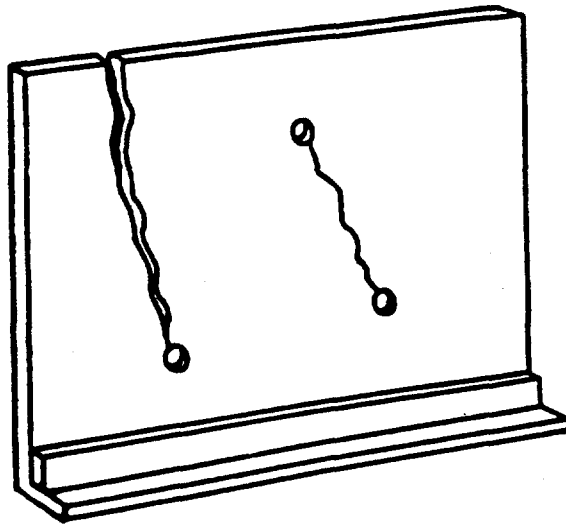

PED/SDC-29

FIGURE 8-2. Controlling Cracks.

e. Caulking torn seams. Among the most difficult holes to plug are torn seams or loose bounding boards where deck and bulkhead plates are joined. It is not advisable to weld leaky riveted seams because the intense heat will cause adjacent rivets to leak. Rags, oakum, marline, soft wood wedges, shingles, lead strips, lead wool, and various plastics have been used to plug such leaks, and even metal caulking. These materials are applied on the unflooded side, but because the plates work, the cracks open and close. This usually permits the plugging materials to be washed out.

f. Doors and hatches sprung by blast. Doors and hatches often are sprung by blast, especially if they were not properly secured. Often the closure can be made tight with shoring. If small spaces are open between the closure and the knife edge, these can be treated as cracks. In some cases, the damage is so bad that it is better to remove the closure entirely and to replace it with a mattress backed by a shored plate.

g. Leaky stuffing tubes and shaft glands. Stuffing tubes around electric cables and reach rods frequently leak, either because they were not properly packed or because the packing has hardened with age. Sometimes it will suffice to tighten up on the packing nut. Marline, oakum, and very small wedges have been used effectively. Action must be taken to insure that they are properly packed at all times and checked with periodic air tests.

Leaky shaft glands have been repaired by tightening up on the nuts. In others, the studs have been broken so it was necessary to shore the whole gland back in place, preferably with welded braces. In one case, the leak was so bad that the repair team made a type of a box patch in two sections, secured it around the shaft, and welded it over the gland. In effect, the ship's repair team made a new gland.

Section V. STRENGTHENING BEAMS AND FRAMES

8-11. METHODS. Beams, frames, and decks, and some bulkheads are strength members of the hull structure and if they break or become weakened, the hull may collapse and the ship break in two and sink. A small ship may not have the necessary equipment to weld on heavy rails or angle irons about the ship to give additional support, but some

help can be obtained by shifting weights to reduce the strain, and by shoring. Beams and frames can be patched or strengthened by bolting or welding doubling plates or bars along the webs. FIGURE 8-3 shows how beams and frames may be ruptured or weakened and illustrates methods for strengthening these vital structural parts of the ship.

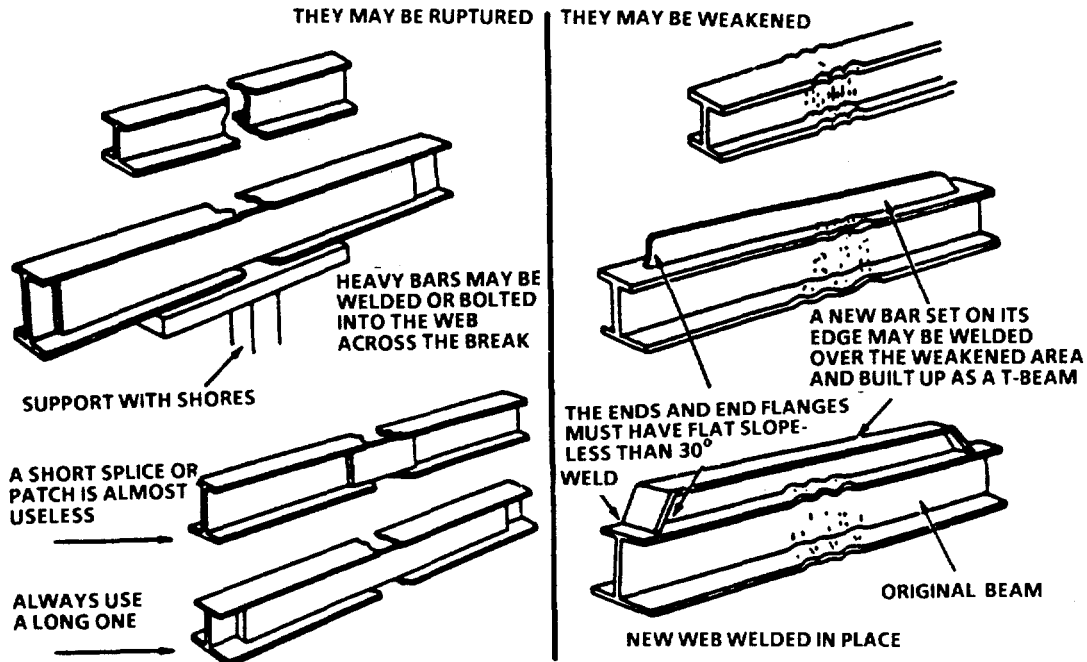

FIGURE 8-3. Strengthening Beams and Frames.

Supports for heavy equipment may be pushed back into place with screw jacks and shoring and later secured with stanchions made of heavy pipe welded in place. Chainfalls and heavy wires, possibly fitted with turnbuckles, may be found useful in pulling plating and equipment back to their original positions. Supports under dislocated machinery often must be carried down several decks because a single deck may not have the strength to support all the weight. It may be necessary to make successive supports down to the bottom frames.

In shoring heavy weights, the butt of the shore is to be placed on a solid frame, or the weight spread between two or three frames by the use of sholes and cross-timbers.

Section VI. REPAIRING PIPE LINES

8-12. **METHODS.** Before starting to repair any pipe line, it may be necessary to remove pressure from the line and provide an auxiliary service.

- a. Types of ruptures. The definitions of the various types of ruptures that could occur to piping systems are:
- (1) Simple—a rupture with no protruding edges, located on a straight section of pipe.
 - (2) Elbow—a rupture with no protruding edges, located on a curved section of pipe.
 - (3) Severed—a section of pipe that has been completely separated.
 - (4) Compound—a rupture having protruding edges, ruptures in fittings, mangled pipes, and similar piping damage.

The several types of pipe ruptures are illustrated in FIGURE 8-4.

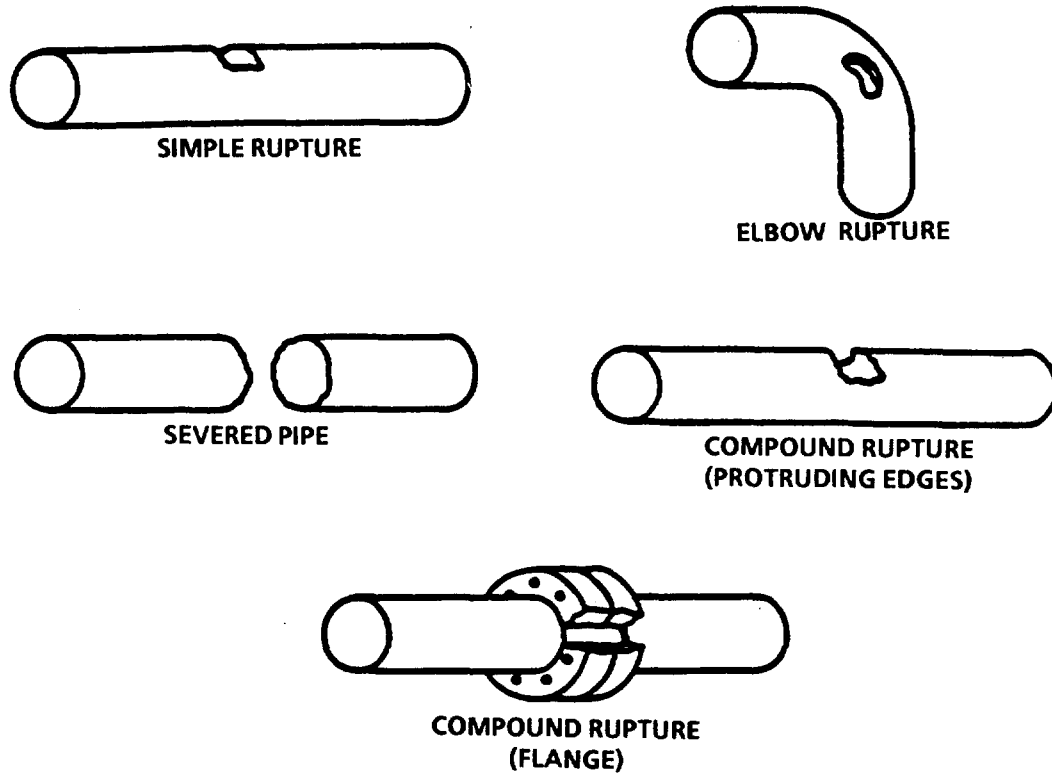

PED/SDC-31

FIGURE 8-4. Types of Pipe Ruptures.

b. Jubilee pipe patch. The jubilee pipe patch is a modification of a commercial hose clamp. FIGURE 8-5 illustrates examples of the application of the jubilee pipe patch.

This patch consists of a piece of sheet metal which is rolled into a cylinder and so shaped at the gap that the two ends are really flanges. These flanges can be reinforced by welding on strips of scrap iron, after which the two flanges are drilled to take from three to five bolts. It is advisable to weld small braces from the flange to the back of the patch to keep the flange faces more or less parallel under pressure.

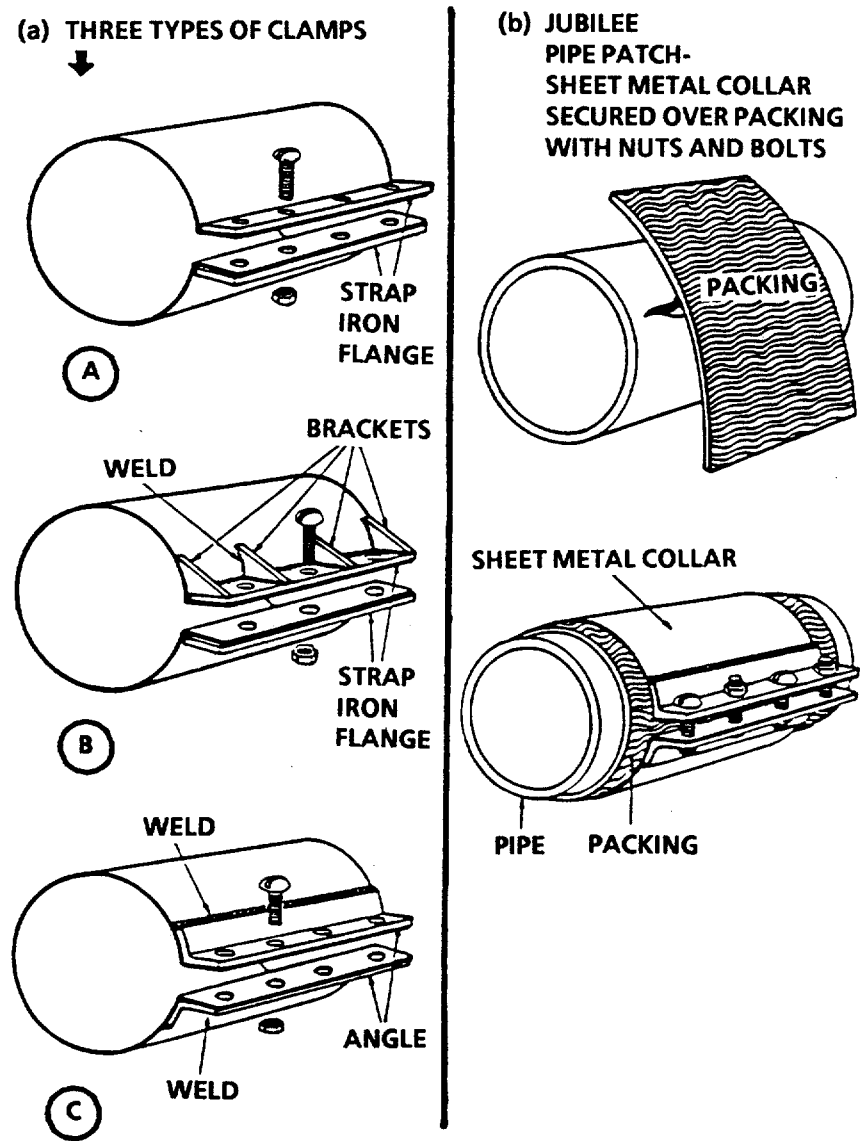

PED/SDC-32

FIGURE 8-5. Jubilee Pipe Patch.

The sheet metal in the body of the patch must be as heavy and strong as possible, but it should be capable of being sprung or bent so the gap will go over the pipe to be repaired. A sheet of packing is first put over the hole, extending well on either side of it. The jubilee clamp is then sprung open and clamped over the packing. When the bolts are tightened, this patch will easily hold upward of one hundred pounds pressure.

Every damage control locker should contain several of these homemade patches in assorted sizes because each patch fits only one size pipe.

c. Soft patches. Small holes or cracks in low-pressure (150 psi.) piping often can be repaired by what are known as soft patches. Examples of the application of soft patches on a low-pressure pipe line are shown in FIGURE 8-6.

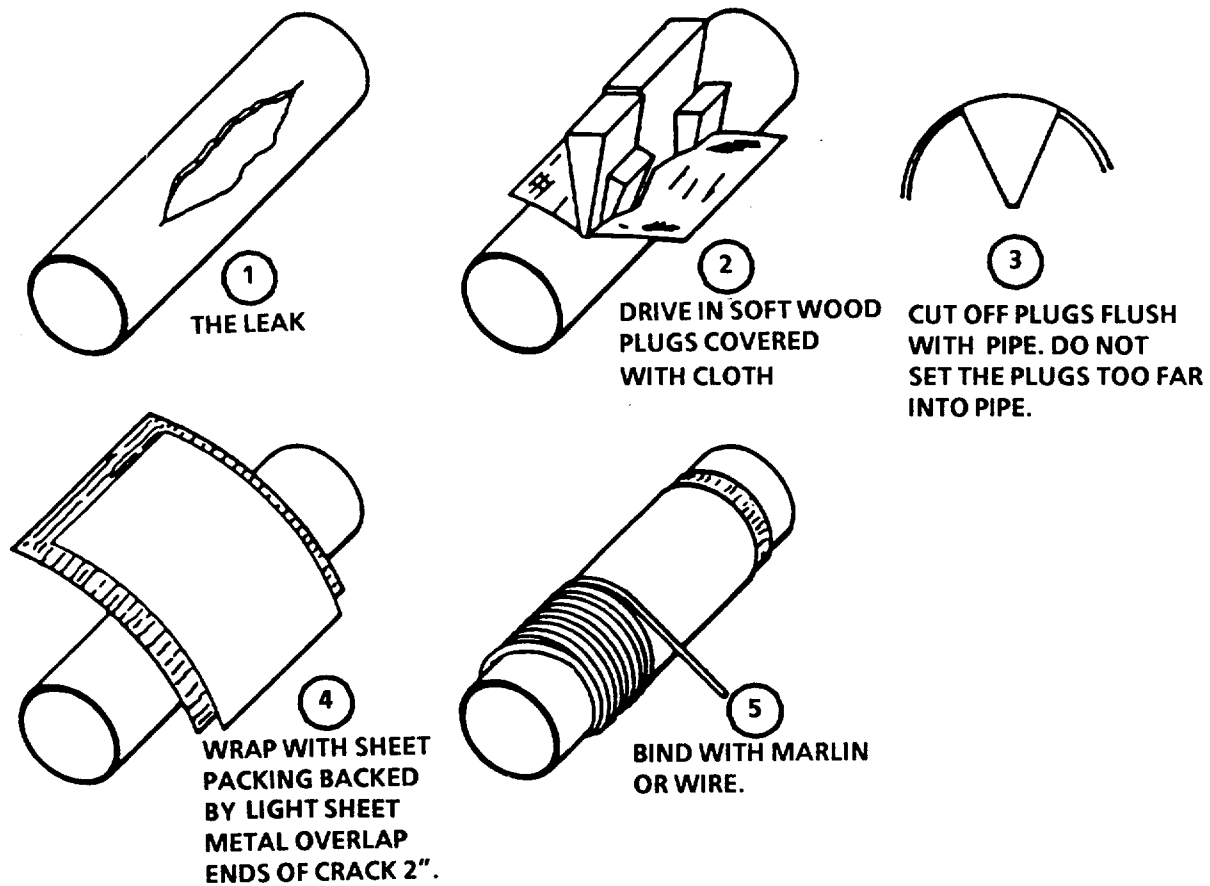

FIGURE 8-6. Soft Patch on Low-Pressure Pipe Line.

When possible, first reduce the area of the hole by driving in softwood wedges. They are not to be driven in too far or they will retard the flow of fluids. The wedges are then to be trimmed flush with the outside of the pipe, after which the area is to be covered with a strip of sheet or rubber packing tightly held in place by two layers of marline or wire. The packing must extend about 2 inches on either side of the hole.

WARNING

The use of white lead or red lead paint on any fresh water pipe is prohibited, even in an emergency, due to the potentially toxic hazard of addition of lead to water that may be used for drinking. Personal injury could result.

The soft patch can be modified or improved to suit immediate conditions. Often it is advisable to have a curved plate of lightweight sheet metal between the packing and binding. A coat of white or red lead on the face of the packing also helps. Small solid rubber balls also can be used to patch holes in pipes. The ball is placed over the hole and secured by banding, wiring, shoring, -or wedging.

Marline and oakum have been used successfully as a caulking material in cracks. In many cases, as on sharp curves, it is not possible to use sheet packing, but combinations of wedges, marline and various plastics will often make effective patches.

d. Wooden plugs. Wooden plugs covered with cloth have stopped many jagged holes in piping. Sometimes, combinations of plugs may be used. Set up on the plugs with a hammer and try to secure them in place with clamps or wires. Otherwise they may work out under pressure. If the hole is not too large, it may be drilled and tapped for inserting a screw plug.

e. Thumb clamps and C-clamps. C-clamps and thumb clamps may be used to hold plugs or patches in place. For example, a block of soft wood may be rough-shaped to fit over a damaged area in a pipe, and the pad may be held in place tightly with two thumb clamps. Care must be taken to reinspect patches held in place by clamps as they have a tendency to work loose under shock or vibration.

f. Caulking with hammer and chisel. Light caulking with hammer and chisel has sometimes been used to close small crack leaks, especially adjacent to flanges. There is always a danger of opening the crack even wider.

g. Welding and brazing. Welding, brazing, and silver soldering can be used to repair leaks, especially at the joint between pipe and flanges. However, these methods are slow, are not reliable in the hands of unskilled personnel, and may lead to fires and explosions. Therefore, their use in combat is limited.

h. Gasoline or other flammable fluid lines. Soft patches are not recommended for gasoline or other flammable fluid lines because the slightest leak would create a tremendous fire hazard. It is far safer to renew the damaged section. The plastic patch can be used as an emergency repair.

i. Renewing piping. If the pipe has been badly holed or ruptured, patching may not suffice and it may be necessary to renew a section. It is advisable to carry spare sections of the smaller sizes of important pipe. In an emergency, it may be possible to remove a section from an unimportant system to use where the need is more urgent. If the original pipe was fitted with screw flanges, remove the entire damaged section, cut screw threads on the new piece, screw the flanges onto the new piece, and install it. The flanges are bolted together. To renew only the damaged part of a small pipe, cut out the damaged area with hacksaws, and cut a piece of pipe almost the same length as the gap. Cut screw threads on all exposed ends of pipe and make up the joints by using pipe unions and couplings. Cut the filler piece short enough to permit inserting the pipe fittings. White lead may be used on screw threads to seal the joint.

Unions may be improvised similar to the soft patches previously described. If the joints are not held together, they may be pushed apart by pressure reaction. It is advisable to force the joints together by means of lines, shores, or wedges.

j. Metal clamping tool. The metal clamping tool, usually referred to as the band-it clamp, has many uses in the repair of piping. It is comparatively simple to operate and produces a very effective repair when applied as indicated in FIGURES 8-7 and 8-8.

The metal clamping tool is supplied in a kit which consists of the following items:

- (1) Steel bands in 100-ft. lengths, and in widths of 3/8-inch (breaking strength 900 pounds) to 3/4-inch breaking strength 2400 pounds).
- (2) The metal clamping tool which tightens and cuts the steel bands.
- (3) Steel buckles.
- (4) Strongbacks-2-inch, 3-inch and 4-inch pipe.

k. Blanking lines. Ruptured pipe lines often are a menace because they cannot readily be isolated and continue to perform a vital function within the piping system. In the case of firemain, the choice may lie between flooding a compartment or extinguishing a fire. Frequently, in the case of oil lines, important and undamaged machinery must be secured. Such problems have been solved by blanking off part of the pipe line. Low-pressure pipe lines often can be blanked by driving wooden plugs covered with cloth. Unsupported, these plugs have a tendency to back out. Adequate support generally can be provided by using shores or jacks, or by drilling a hole through the pipe and pinning the plug in place. For frayed ends of pipe cut by fragments, combinations of plugs may be desirable. When the damaged pipe is joined by screw fittings, it is a simple matter to unscrew the damaged part and to stop the flow of fluid by means of a pipe cap or a pipe plug.

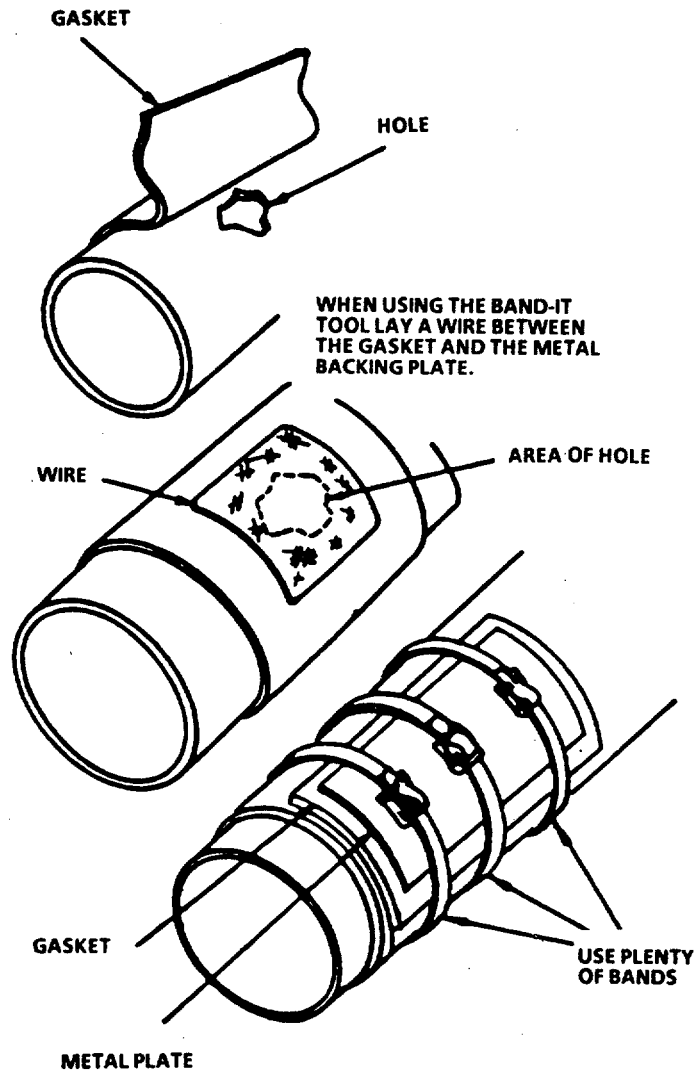

PED/SDC-34

FIGURE 8-7. Metal-Banded Patch.

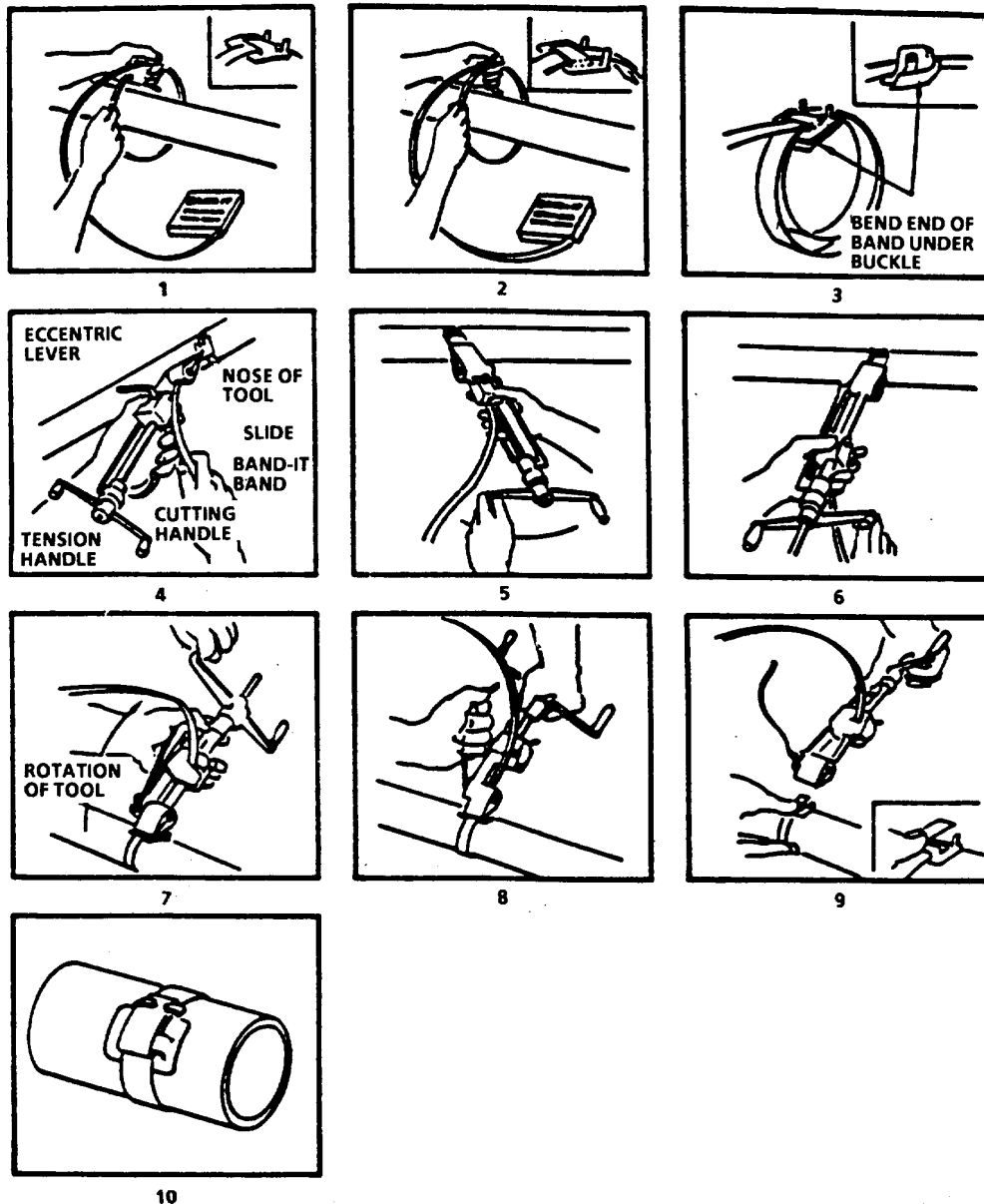

PED/SDC-35

1. Thread band through buckle.
2. Preferably wrap twice around.
3. Bend end of band under buckle.
4. Apply tool to band.
5. Release tension handle with slide forward.
6. With thumb on eccentric, apply tension.
7. Then rotate tool over buckle.
8. Back off with tension handle throughout rotation of tool.
9. Cut.
10. Remove tool. Keep thumb on stub to avoid slipping until stub is forced down between ears which are hammered down securely.
11. Complete Band-It clamp.

FIGURE 8-8. Metal Banding.

Section VII. DAMAGE CONTROL METALLIC PIPE AND GENERAL REPAIR KIT (PLASTIC)

8-13. DESCRIPTION. All water, fuel, and gas lines can be repaired and service restored to the system by use of the Damage Control Metallic Pipe and General Repair Kit (Plastic). The complete kit contains the following:

a. Assembly 1: P/N MILR17882 Assy 1; NSN 4730-00-542-3359

- (1) 4 cans of liquid resin, 400 grams each.
- (2) 4 cans of liquid hardener, 100 grams each.
- (3) 1 piece of woven roving cloth, 24 x 10 inches.
- (4) 1 piece of void cover, 8 x 36 inches.
- (5) 1 piece of PVC film, 36 x 72 inches.
- (6) 1 chalk line, 1/8 pound.
- (7) 4 pairs of gloves.
- (8) 2 eye shields.
- (9) 4 spatulas, wood.
- (10) 1 pair of scissors.
- (11) 1 instruction manual.

b. Assembly 2: P/N MILR17882 Assy 2; NSN 4730-00-542-3362

- (1) 4 cans of paste resin, 300 grams each.
- (2) 4 cans of past hardener, 75 grams each.
- (3) 4 depressors, wood, tongue.

8-14. PLASTIC PIPE ADVANTAGES. The principal advantages of the plastic patch in damage control are:

- a. Versatility.
- b. Simplicity.
- c. Effectiveness.
- d. Speed of application.
- e. Durability.

The plastic is versatile because the patch can be successfully applied to piping systems, fittings, bulkheads and decks, and (in paste mixtures) used as a filler for cracks and small (1-inch) holes where the pressures are under 300 lb./in.²

and the temperature does not exceed 200° F. The patch has excellent adhesive qualities when applied to ferrous and cuprous metals and can be employed for emergency repairs to a variety of damaged structures having smooth or jagged protruding edges. Plastic patches can be applied under conditions which delay repairs by other methods and in many cases require permanent repairs or replacements before service can be restored to the damaged system.

The preparation and application of the plastic patch can be accomplished with basic knowledge and training. The application of the pipe or surface patch is comparable to that of a battle dressing in first aid, and the use of the paste is as simple as applying putty.

Plastic patches, when properly applied, are completely effective. In those infrequent instances when defects occur, the leakage may be found at the extremities of the patch, between the patch and the metal surface. Such leaks generally are less than one percent and do not become greater. Defects, when they occur, generally are attributed to faulty preparation or application.

It can be assumed that the speed of application of a plastic patch is basically determined by the size and type of rupture and the local working conditions. A simple type patch can be applied to a 4-inch pipe in less than 10 minutes. Various types of damage may require varying preparation times, but once the patch is properly in place, the type and size of the rupture or the size and shape of the structure have little effect on the time involved.

The maximum patch life has not been determined, but all indications are that a properly applied patch will last until such time as a permanent repair or replacement can be made. However, it must be understood that the patch is an emergency expedient and is not intended, or should it be considered, a substitute for a permanent repair. The patch is relatively inert, being adversely affected only by excessive (200° F.) heat and concentrated acids.

The success of a properly applied patch is dependent upon two factors, strength and adhesion, and with these two factors present, the patch will be completely effective. In the process of curing, the patch will have the tendency to adhere well to metal and other surfaces. The process of applying the plastic patch actually reinforces the activated resin with fibrous glass material. The reinforcement of the resin greatly increases the strength when the patch is cured.

Should fibrous glass materials not be available, reinforcing can be accomplished by the use of cloth such as a blanket or some other material which will absorb the resin. In most cases, reinforcing with such material will not provide the equivalent strength obtained through the use of fibrous glass materials. Although substitute materials are highly effective, they are to be used only when materials herein specified are unavailable.

8-15. TYPES OF PATCHES. Several types of patches are possible for repairing pipes and bulkheads in diverse locations and with diverse uses. They are described in the following paragraphs:

a. Pipe patch. The components of the repair kit normally used for repairing a pipe in the piping system are the liquid resin and liquid hardener mixture together with the prescribed fibrous glass material. This mixture is approved for patching the following piping systems:

- (1) Fresh water.
- (2) Salt water.
- (3) Fuel oil, lubricating oil, diesel oil.
- (4) Gasoline.
- (5) Refrigeration.

b. Flat patch. This patch is the metallic and nonmetallic surface repair patch. The flat patch utilizes the same components as the pipe patch. The mixture is approved for patching the following metallic and nonmetallic surfaces:

- (1) Metal bulkheads and decks.
- (2) Tanks, voids, and cofferdams.
- (3) Wood surfaces.

c. Paste patch. This patch also is a metallic and nonmetallic surface repair patch. The material normally used for patching small holes, cracks, fillets, and so forth, is the paste resin and paste hardener mixture. The paste mixture was developed primarily for small holes and cracks under one inch in diameter. In many respects, the paste mixture has the same general characteristics as the liquid mixture. The paste mixture is approved for patching, but is not limited, to the following:

- (1) Sea chests.
- (2) Valve bodies.
- (3) Pump casings.
- (4) Cooling water jackets.
- (5) Condenser heads.
- (6) Flanges.
- (7) Caulking for leaking seams and rivets.
- (8) Porous castings.
- (9) Threaded joints.

8-16. DESCRIPTION OF BASIC MATERIALS. The basic materials used in patching are described in the following paragraphs:

a. Resins and hardeners. The liquid and paste resins are of the epoxy type. The liquid and paste hardeners are chemical compounds used to harden the resins. These ingredients are packaged in prescribed amounts. When the hardeners and resins are mixed, a chemical reaction occurs which causes the mixture to harden. The liquid mixture sets in approximately 12 minutes, the paste mixture in approximately 17 minutes.

WARNING

Do not mix hardener with resin until all preparations have been completed and do not intermix liquid resin and paste hardener, or paste resin and liquid hardener. Do not mix resin or hardener from any other source with those supplied in this kit. Improper use may cause violent chemical reactions which can cause serious personal injury.

b. Void cover. This is resin-treated glass cloth that can be cut and formed to cover and support the patching materials over a damaged area.

c. Woven roving cloth. This substance is made of a short staple, glass fiber woven into a thick fluffy cloth. During the application of a plastic patch, this cloth is coated with the resin hardener mixture and wrapped around or placed over the damaged section. This cloth provides the principal strength of the patch and provides a method of applying the resin hardener mixture.

d. Film (PVC). The film is a thin, transparent, polyvinyl chloride material used as a separating film for a flat patch to prevent the patch from adhering to the backup plate or supports. In pipe patching, it is used to cover the entire patch and retain the activated resin around the patch. In this application, it is described as a retaining cover. Kraft wrapping paper or Mylar can be substituted as retaining covers.

8-17. PATCH APPLICATION SEQUENCE. During the several steps in the application of the different patching materials, the area covered gets progressively larger. FIGURE 8-9 illustrates the position of patching materials relative to

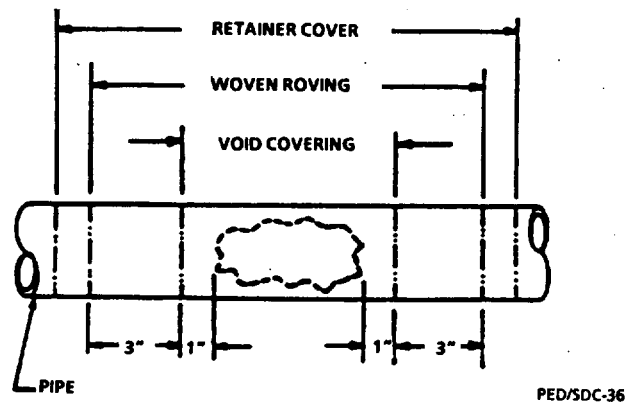

FIGURE 8-9. Sequence of Applied Patch Materials.

This buildup in patch length during applications must be considered initially in determining the length of patch to be applied. Where practical, allow the patch to extend 4 to 5 inches on each side of the rupture. With a severed pipe, the length of the patch must be considered to be longer than in the case of a simple pipe patch.

8-18. QUANTITY OF MATERIAL REQUIRED. After the decision has been made as to the type and size of the patch to be applied and the pipe has been prepared, the following formulas can be used to determine the quantities of basic materials that will be required.

$$R - WR \times 2$$

$$WR - C \times 4$$

where: R - Active resin (grams)
 WR - Woven Roving (in square inches)
 C - Circumference of pipe

Note: The width of WR-length of patch

8-19. FLAT PATCH (LIQUID). The simple flat patch is approved for making plastic repairs to ruptures in metallic and nonmetallic surfaces.

Ruptures up to and including 12 inches in diameter, or square, successfully can be repaired by using procedures similar to those employed in making pipe repairs. For ruptures more than 6 inches in diameter, the patch overlap should increase 1 inch for each inch of increased diameter. The greater the overlap, the larger the area to which the patch will adhere and thus increase the total strength of the patch. FIGURE 8-10 illustrates a patch over a 12-inch hole.

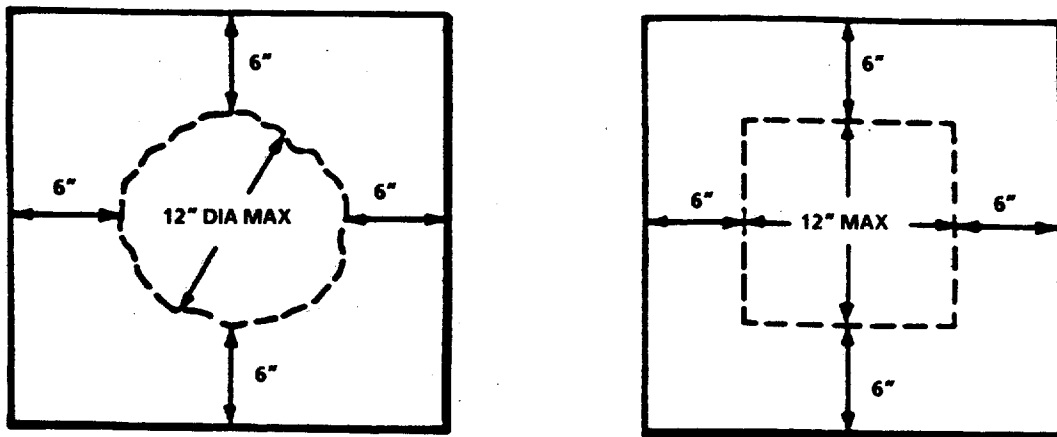

PED/SDC-37

FIGURE 8-10. Patch Size for 12-Inch Hole.

8-20. APPLICATION TO VERTICAL SURFACE. The sequence in the application of a simple flat patch to a vertical flat surface, shall be:

- a. Follow carefully all preparation instructions. Use goggles and gloves provided with the repair kit.
- b. Lay the first ply of woven roving cloth of a flat surface. Starting at one end, pour the resin hardener mixture, spreading evenly with a spatula over the entire area. Work toward the opposite end. Care should be taken to ensure that the edges are well impregnated.
- c. Coat the surface to be patched by rubbing with impregnated cloth.
- d. Center the impregnated cloth over the damaged area.

NOTE

Center the next ply over the preceding one and use the spatula to work out air bubbles and wrinkles.

- e. Position the PVC covering over the plastic patch and press firmly.
- f. Position the backup plate over the plastic patch and press firmly.
- g. Position the necessary strongbacks and shoring to hold the backup plate in place.

CAUTION

When the temperature around the patch is below 50° F., the careful application of heat from infrared lamps will speed up the curing of the patch. Excessive heat may make the patch porous and impair its effectiveness.

8-21. APPLICATION TO OVERHEAD OR HORIZONTAL SURFACE. In the application of a flat patch to the overhead or the underside of horizontal flat surfaces, vertical flat surfaces must be prepared with additional precaution taken to support the weight of the patching materials as they are being applied. Because of weight, the successive layers of impregnated (liquid resin hardener) woven roving cloth will have a tendency to pull away from the area to be patched. For this reason, a minimum of two men should be employed during these operations. FIGURE 8-11 illustrates the overhead or horizontal flat surface patch.

8-22. PASTE PATCH. The paste resin paste hardener mixture can be used for repairs to cavities, cracks and small holes. It is suitable for repairs to small bulkhead holes such as those resulting from the removal of electric cables, small fuel oil tank ruptures, small piping system ruptures, and the cracked water end casing of reciprocating fire and bilge pumps. It also is recommended for such emergency repairs as eroded or ruptured centrifugal pump casings, and the like. It should not be used for holes larger than 1 inch in diameter because the uncured resin may sag, fall through or pull away. When cured, the paste mixture is less shock-resistant than the liquid resin used with glass reinforcement.

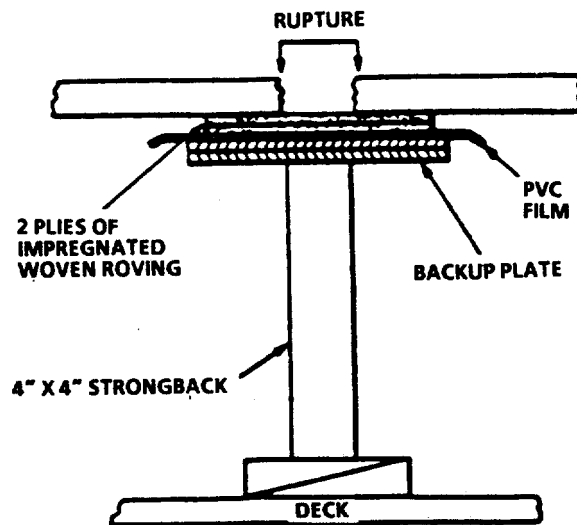

FIGURE 8-11. Overhead or Horizontal Flat Surface Patch.

In general, for maximum strength, repair with the glass reinforced liquid hardener system.

- a. Preparation. The following preparations must be made prior to the application of the plastic patch.

WARNING

Trichloroethane vapor, when used in poorly ventilated and confined spaces may result in damage to the lungs, eyes, and skin, and is toxic if taken internally. Avoid any prolonged or repeated breathing of the vapor or contact with the skin. In addition, the evaporative products resulting in the heating of trichloroethane are more toxic than the unheated liquid, so caution must be taken not to use trichloroethane on any heated surfaces.

- (1) Clean the area adjacent to the rupture to ensure it is free of oil, grease, dirt, paint, and other foreign matter. If grease or oil is present, use an approved cleaning solution such as Stoddard or trichloroethane (methyl chloroform). If neither of these solvents is available, scrape and wipe free. When a clean surface is obtained, the surface may be further abraded for better adhesion using the abrasive cloth furnished with the kit.

NOTE

The surface to be cleaned should extend approximately 1 inch beyond the entire periphery of the rupture.

(2) Make sure that the ruptured surface is dry.

(3) Determine the amount of paste resin and paste hardener that will be required. For example, one can of paste resin (300 grams) mixed with one can of paste hardener (75 grams) is sufficient to fill a ruptured area 1 inch thick by 4 inches square (16-cubic-inch volume).

b. Application. The simple paste patch is applied in the following sequence to vertical overhead or underside or horizontal surfaces.

(1) Follow carefully all preparation instructions (using facing shields, goggles, and gloves provided with the kit).

(2) Remove the paste resin and paste hardener from containers and mix on a flat surface, using only an amount sufficient to make each repair.

(3) Apply paste mixture to the rupture, applying sufficient pressure to force the mixture into and through the entire thickness of the ruptured material (extruding slightly as shown in FIGURE 8-12), leaving a convex working surface extending approximately 1 inch beyond the entire periphery of the rupture.

(4) Place the PVC film over the paste mixture and smooth over lightly. The PVC may be removed after the mixture is cured.

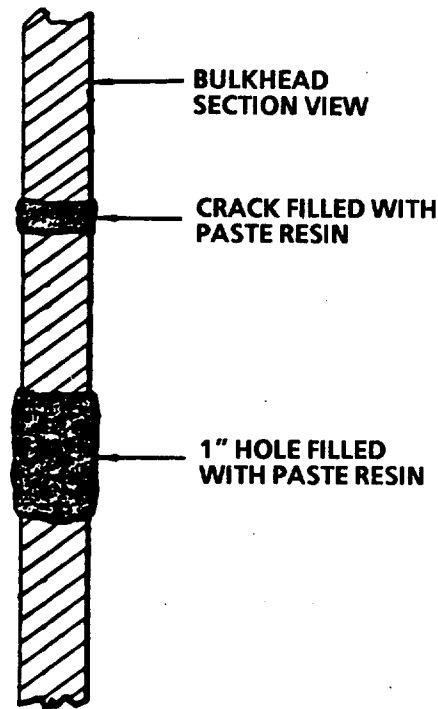

PED/SDC-39

FIGURE 8-12. Bulkhead Repair.

Eroded piping, internal pump casings, condenser heads, and tube sheets can be repaired temporarily with the paste mixture. The application of the paste mixture with modifications suitable to the individual repair is substantially the same regardless of the type of small crack or cavity involved. For all such minor repairs, after proper preparatory action has been taken, the application consists principally of troweling, squeezing, or molding the paste mixture to conform to the defective area.

8-23. LIQUID-PASTE COMBINATION PATCH. Situations may develop where it is desirable to use the liquid resin hardener mixture, reinforced with roving cloth, in combination with the paste resin hardener mixture.

The woven cloth can be applied to either side of the paste resin hardener mixture used to fill the cavity (as illustrated in FIGURE 8-13). One ply of impregnated woven roving on one side of the surface being repaired is sufficient. When it is desirable to present a finished side, it is preferred that the paste be applied to that side as it can be sanded or ground to conform to surface contours after it has hardened. Where it is practicable, it is best to apply the woven roving on the pressure or impact side of the hole.

Combination patch may be employed:

- a. Where insufficient quantities of material for either single type patch (liquid or paste) are available.

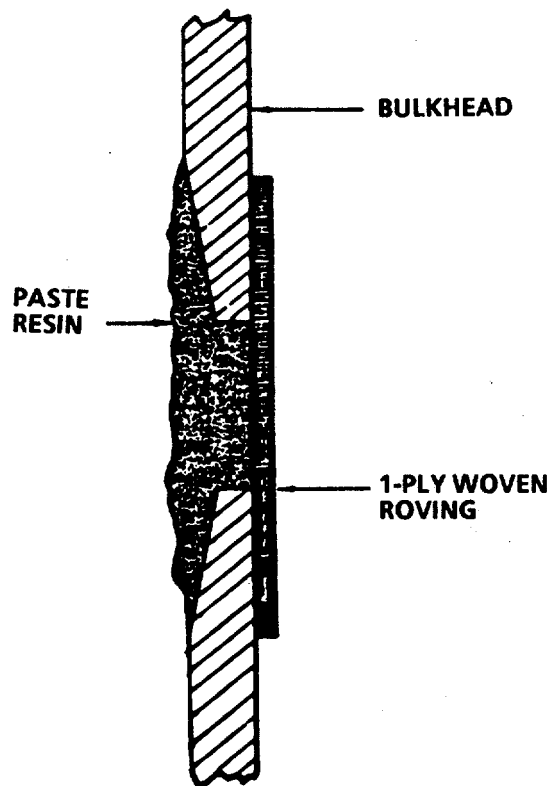

PED/SDC-40

FIGURE 8-13. Combination Patch Repairs to Metal or Wooden Bulkheads.

b. Where an individual patch has been applied with unsuccessful results. Either type patch may be used as a supplementary repair.

Where the ruptured area cannot be isolated, the paste mixture prior to curing acts as a temporary seal, after which the liquid impregnated cloth is applied as a permanent repair. This is based on the premise that the paste mixture will not wash away as readily as the liquid.

In a compound rupture, paste may be used as a filler to form a flat surface so the woven roving can be applied to form a flat patch.

8-24. SUGGESTIONS FOR USING PLASTIC REPAIRS. Both the paste and liquid resins with their associated hardeners always are mixed in the same proportions: four parts of resin to one part of hardener. The resin and hardener are packaged in their proper ratio. Add the hardener to resin and mix thoroughly until a uniform gray color is observed. It is advisable when mixing paste resin and hardener to remove the substances from the can and mix them on a dry, clean board; in this way, uniform color of mix can be more easily observed.

One large can of liquid resin, 400 grams, when mixed with 100 grams of liquid hardener will give a total of 500 grams of activated resin, which is sufficient to thoroughly impregnate one strip of 6-inch by 40-inch woven roving. Two grams of resin hardener mixture will impregnate 1 square inch of woven roving cloth. Determine the quantity of resin hardener mixture required to impregnate the amount of woven roving to be used.

Do not mix resin and hardener until all other preparations have been completed.

WARNING

Heat and fumes are given off when using plastic repair materials. Chemicals can cause serious burns to eyes or exposed areas of skin. Wear gloves provided to protect hands and face shield to protect the eyes when making any repairs involving the use of plastic resins. In the event resins do come into contact with any part of the body, wash with large quantities of hot water and soap and seek medical attention. Personal injury could result.

The patch should not be subjected to any pressure until the temperature of the patch has dropped below 150° F.

8-25. PATCHING SAFETY PRECAUTIONS. Provide forced air supply and exhaust ventilation during the time plastic materials are being used. This is most important during the time that heat and the resultant fumes are given off. Also follow these precautions:

- a. Prior to using plastic, use protective rubber gloves.

- b. Only crew members in good health and free of any respiratory conditions or skin lesions should be exposed to plastics.
- c. Immediately relieve and treat anyone evidencing sensitization.
- d. Wash all equipment with hot water and soap.
- e. Change clothes and shower after completion of work.
- f. Scrub down with a good natural skin detergent before securing and leaving the area. Wash hands frequently.
- g. Keep fingernails trimmed short and clean.
- h. Do not expose yourself to or breathe the noxious fumes given off during cure.
- i. Avoid spilling plastic materials. Keep kraft paper in areas where material is likely to spill or drip.
- j. Keep resin and hardener off skin areas whenever possible and use protective ointment. If contaminated, remove material as feasible, using hot water and soap.
- k. Keep resin and hardener out of eyes; if contaminated, immediately rinse with water and obtain medical treatment.
- l. Remember always that a continuous high state of personal cleanliness is your most important and effective protection. Wear gloves and goggles provided in this kit.
- m. Resin and hardeners are available on most ships which are incompatible with those provided in these kits. Do not mix resin or hardener from any other source with those supplied in the repair kit. There is a probability that a violent reaction will occur if resins and hardeners are interchanged.

CHAPTER 9

ELECTRICAL POWER AND LIGHTING

SDC FIXES SHALL BE USED ONLY IN COMBAT OR OTHER EMERGENCY CONDITIONS AT THE DISCRETION OF THE VESSEL MASTER. DAMAGE SHALL BE REPAIRED BY STANDARD MAINTENANCE PROCEDURES AS SOON AS PRACTICABLE.

Section I. GENERAL INFORMATION

9-1. ELECTRICAL POWER. Electrical power is indispensable to the LCU's functional effectiveness. Electrical power furnishes light, runs vital auxiliaries, helps turn the rudders, and operates the radar, radios, and a host of other equipment.

Section II. NORMAL ELECTRICAL POWER

9-2. SUPPLY. Normal electrical power is supplied by two Cummins NT-855-GC2 Marine Generator Sets. Each generator is rated at 240 Vac, 250 kW. One generator can be operated by itself to provide electrical power, or both generators may be run in parallel. These two generators supply power to the main switchboard, which in turn supplies various equipment, distribution panels, and the emergency switchboard during normal operation.

Power may also be taken from an off-hull source via a shore power connection which taps into the main switchboard. An interlock prevents parallel operation of the main generators and shore power. There are two shore power connections on the main deck centerline on the forward bulkhead of the deckhouse. There are two 75-foot lengths of cable supplied with the ship.

Wiring circuits may be severed by blasts, fragments, and structural damage. Wiring repair should only be accomplished where it is essential for returning to port. Splicing of wires should be done whenever possible. Open circuits can sometimes be repaired by inserting a new wire (jumper wire) that bypasses the problem area. If wire is not available in shipboard storage, it may be necessary to salvage wire from non-essential or inoperative systems.

Section III. POWER DISTRIBUTION

9-3. DISTRIBUTION. The distribution feeders originate at the main switchboard and supply power to distribution panels or, in some cases, directly to individual auxiliaries. In turn, the power distribution panels distribute to the individual auxiliaries. FIGURE 9-1 shows normal power distribution.

During flooded conditions, whenever possible the power should be removed from the affected area from the main or emergency switchboard. Power should not be restored until the water has been removed, circuits properly dried, and an inspection made to ensure safe electrical conditions.

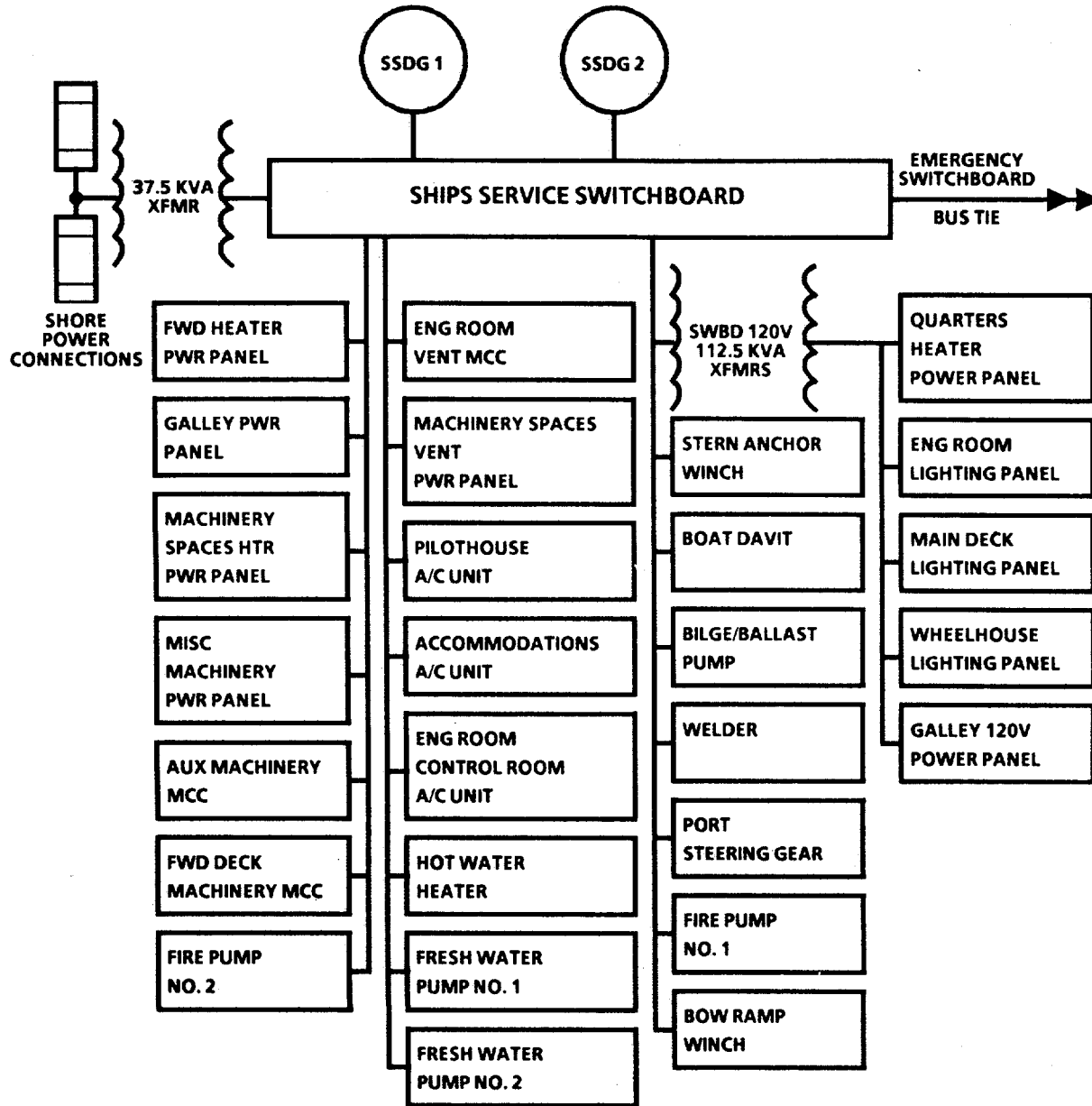

FIGURE 9-1. Normal Power Distribution.

Section IV. EMERGENCY ELECTRICAL POWER

9-4. SUPPLY. Emergency power is supplied by a Cummins 4BT 5.9GC Marine Generator Set. The emergency generator is rated at 240 Vac, 40 kW, and supplies only the vital equipment which is fed by the emergency switchboard. FIGURE 9-2 shows emergency power distribution.

Section V. EMERGENCY POWER OPERATION

9-5. EMERGENCY POWER. In the event of loss of normal power, the Emergency Generator will automatically start and energize the emergency switchboard within 45 seconds by use of ABT (Automatic Bus Transfer) equipment. The following is a list of vital equipment that is fed through the emergency switchboard and will remain in operation even after normal power is lost.

<u>EQUIPMENT</u>	<u>POWERED FROM</u>
Generator Jacket Water Heater	Emergency Switchboard
Fuel Oil Transfer Pump	Emergency Switchboard
Starboard Steering Gear	Emergency Switchboard
MSR 6212 Power Supply	Emergency Switchboard
Radar Distribution Power Panel	Emergency Switchboard
Wheelhouse Lighting Panel	Emergency Switchboard
Wheelhouse IC/ELEX Panel	Emergency Switchboard
Emergency Lighting Below Main Deck	Emergency Switchboard
AN/URC-80 Radio Battery	Emergency Switchboard
Bow Thruster Battery Charger	Emergency Switchboard
SSDG 1 Battery Charger	Emergency Switchboard
Emergency Generator Battery Charger	Emergency Switchboard
Emergency Switchboard Battery Charger	Emergency Switchboard
AN/URC-46 Radio	Emergency Switchboard Batteries
Bow Thruster Steering Pump	Emergency Switchboard Batteries
Fire Detection System	Emergency Switchboard Batteries

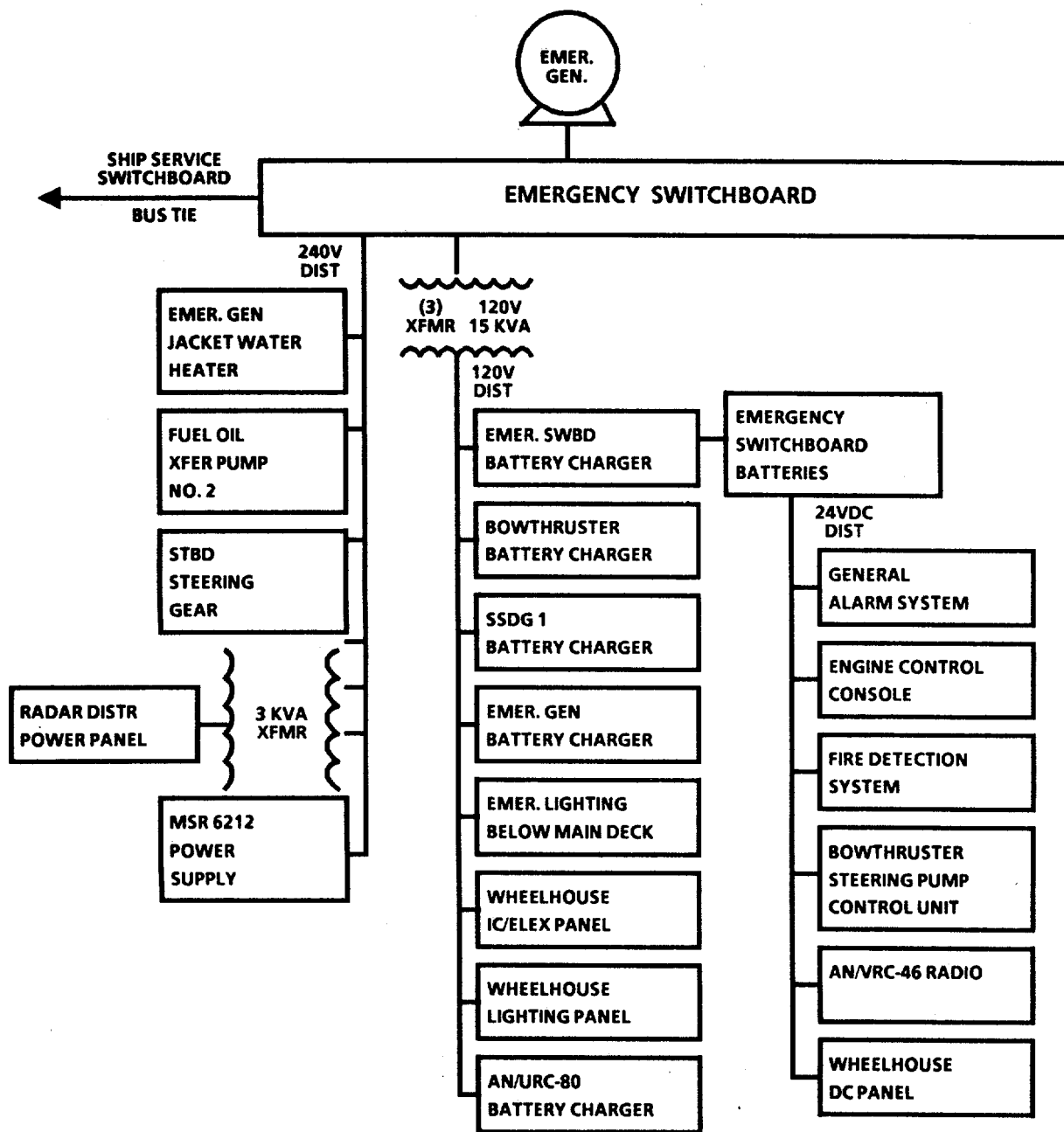

SDC 002 (G-365A) 11/23/88

FIGURE 9-2. Emergency Power Distribution.

EQUIPMENT

POWERED FROM

Engine Control Console	Emergency Switchboard Batteries
General Alarm System	Emergency Switchboard Batteries
Wheelhouse D.C. Panel	Emergency Switchboard Batteries
Audio Frequency Amplifier AM-6747/V	Wheelhouse D.C. Panel
AN/APX-72 IFF Transponder	Wheelhouse D.C. Panel
MK 27 Power Transformer Unit	Wheelhouse D.C. Panel
Ship's Control Console	Wheelhouse D.C. Panel
Magnetic Compass Lighting	Wheelhouse D.C. Panel
Yardarm Blinkers	Wheelhouse D.C. Panel
Suez Canal Light Receptacles	Wheelhouse Lighting Panel
Life Raft Floodlights	Wheelhouse Lighting Panel
14" Searchlights	Wheelhouse Lighting Panel
Aldis Signal Lamps	Wheelhouse Lighting Panel
Intercom, 26 MC	Wheelhouse Lighting Panel
Chart Table Light	Wheelhouse Lighting Panel
Clearview Screen Heater	Wheelhouse Lighting Panel
Emergency Lighting Main Deck and Above	Wheelhouse Lighting Panel
Ship's Control Console	Wheelhouse Lighting Panel
Whistle	Wheelhouse Lighting Panel

EQUIPMENT

POWERED FROM

Horn	Wheelhouse Lighting Panel
Arms Control Sprinkler Alarm	Wheelhouse Lighting Panel
Fire Detection System	Wheelhouse Lighting Panel
Doppler Speed Log	Wheelhouse Lighting Panel
Navigation Lighting Panel	Wheelhouse Lighting Panel
Elex Control Unit 250-CG	Wheelhouse IC/ELEX Panel
Receiver ADF 4005A	Wheelhouse IC/ELEX Panel
AUX RCVR/XMTR 6100	Wheelhouse IC/ELEX Panel
MK 37 Heading XMTR	Wheelhouse IC/ELEX Panel
MK 27 Power Conversion Unit	Wheelhouse IC/ELEX Panel
Omega Receiver R-2163/SRN-23	Wheelhouse IC/ELEX Panel
Weather Facsimile Receiver	Wheelhouse IC/ELEX Panel
HF (Distress Frequency) Receiver	Wheelhouse IC/ELEX Panel
RT-1277/URC-92 Receiver/Transmitter	Wheelhouse IC/ELEX Panel
Radio Telephone Alarm	Wheelhouse IC/ELEX Panel
SPT Audio/Visual Devices	Wheelhouse IC/ELEX Panel
RPX-150 Battery Charger	Wheelhouse IC/ELEX Panel
"X" Band XMTR/Receiver	Wheelhouse IC/ELEX Panel

EQUIPMENT

POWERED FROM

"S" Band XMTR/Receiver	Wheelhouse IC/ELEX Panel
Secure Communication Panel	Wheelhouse IC/ELEX Panel
FSK Modem Model 1280A	Secure Communications Panel
Security Equipment TSEC/KG-84	Secure Communications Panel
Teletypewriter AN/UGC-74B(V)3	Secure Communications Panel
ARQ Term. Modem 3500B	Secure Communications Panel
Inter Connection Box J-4243/U	Secure Communications Panel
Security Equipment TSEC/KY-65	Secure Communications Panel
HF Exciter MSR 6700	Secure Communications Panel
MSR 5050 Receiver	Secure Communications Panel

Section VI. EMERGENCY LIGHTS

9-6. EMERGENCY LIGHTS. Designated lights in vital spaces provide illumination during emergency conditions. There are 35 emergency lights throughout the ship powered from the emergency switchboard and the wheelhouse lighting panel.

APPENDIX A

References

A-1 Reference Documents.

- a. LCU Trim and Stability Booklet, September, 1988.
- b. LCU Damage Stability Booklet, March, 1988.

GLOSSARY

Clinometer	Instruments for measuring the angles of roll and pitch.
HALON	A halogenated fire extinguishing agent which leaves no corrosive or abrasive residue after use.
List	A temporary inclining of the ship to one side.
Logy	A term to describe heavy and sluggish movement of the ship.
Loll	The tendency of a ship to hang at the end of a roll instead of quickly righting itself.

INDEX

Subject	Paragraph, Figure, Table, Number
A	
AFFF.....	6-18
Alarm Panel (Fire).....	6-25
Lamps.....	6-25
Angle of List.....	5-5
Aqueous Film Forming Foam.....	6-18
B	
Batten.....	7-8
Measuring.....	7-8
Beams, Strengthening.....	8-11
Below Water Damage.....	2-3
Blowers, Portable	
Ventilation.....	6-28
Box Patch.....	8-9
Bucket Patch.....	8-9
C	
CO2 Extinguishers.....	6-16
Combustion Products	
Ash.....	6-12
Fire Gases.....	6-8
Flame.....	6-9
Heat.....	6-10
Smoke.....	6-11
Conditions of Loading	
Standard.....	5-35
Full Load.....	5-35
Beaching.....	5-35
Control Procedures,	
Damage.....	2-7
Corrective Measures for	
Damage.....	2-6
Counter Flooding.....	8-1
Curve of Righting Levers.....	5-37
D	
Damage Control, Defined.....	1-2
Equipment.....	4-2
Location.....	4-3

Subject	Paragraph, Figure, Table, Number
D	
Damage, from Fire.....	2-5
Flooding.....	88-1
Types.....	22-1
Damage Resistance	
Characteristics.....	5-8
Drainage Bill.....	5-11
Dry Potassium Bicarbonate.....	6-14
Dynamic Stability.....	5-6
E	
Effects of Damage.....	5-23
Electrical Power, General.....	9-1
Distribution.....	9-3
Emergency.....	9-4
Normal.....	9-2
Operation.....	9-2
Emergency Lights.....	9-6
Extinguishers, Portable	
General.....	6-15
Operation.....	6-16
CO ₂	6-16
PKP.....	6-17
AFFF.....	6-18
Extinguishing Agents for	
Fire.....	6-14
F	
Fire Fighting, Basic.....	6-19
Equipment.....	6-22
Fire, General.....	6-1
Chemistry and Physics	
of.....	6-2
Class A.....	6-3
Class B.....	6-4
Class C.....	6-5
Class D.....	6-6
Detectors.....	6-25
Protection System.....	6-25
Fire Hazard Materials.....	6-13
Fire Main.....	6-20
Fire Pumps.....	6-20

INDEX

Subject	Paragraph, Figure, Table, Number
F	
Fire Stations	6-20
Flat Patch (Liquid)	8-19
Flooding Effect Bill	5-13
Flooding, General	8-1
Preparations to Resist	5-9
Flooding Load	8-1
Boundaries	8-1
Counterflooding	8-1
Damage	8-3
Hogging	8-1
Sagging	8-1
H	
HALON System	6-24
in Ventilation	3-2
Hogging	8-1
Holes in Hull	
Underwater	8-7
At Waterline	8-8
Hook Bolts	8-9
I	
Intercommunication System	
LS-519A/SIC	4-12
Investigating Flooding	
Damage	8-2
J	
Jettison Ship Bill	5-12
Jubilee Pipe Patch	8-12
L	
Lamps, Remote Alarm	6-25
Leaks and Cracks, Sealing	8-10
Length of Shore	7-7
Life Jackets, Location	4-4
Lights, Emergency	9-6
Limiting Draft	5-34
Liquid Loading Diagram	5-36

Subject	Paragraph, Figure, Table, Number
M	
Manual Fire Stations	6-25
Metacenter, Defined	5-2
Metacentric Height, Defined	5-4
Metallic Pipe and General Repair Kit	8-13
N	
Nuclear, Biological, and Chemical Equipment	4-6
P	
Paste Patch	8-15
Patches, Plate	8-9
Types	8-16
Pipe Repair, Materials	8-12
PKP, Defined	6-17
Extinguishers	6-17
Protection System (Smoke/ Fire Alarms)	6-25
R	
Repair, Pipe	8-12
Repairing Holes in Hull	8-9
Righting Arm	5-3
S	
Safety Precautions, Patching	8-25
Sagging	8-1
Sensor Distribution	6-25
Sholes	7-15
Shore Connections	
Electrical	9-2

INDEX

Subject	Paragraph, Figure, Table, Number
S	
Shoring	7-1
Application	7-10
Bulkheads	7-11
Hatches	7-12
Materials	7-4
Methods	7-3
Preparation	7-7
Tools	7-5
Wood	7-6
Smoke Clearance.....	6-26
Precautions	6-27
Smoke Detectors	6-25
Soft Patches	8-12
Sound-Powered Telephone	
Handset	4-8
Headset	4-9
Location	4-11
Storing	4-10
System	4-7
Sprinkler System	6-20
Stability, Defined.....	5-2
Characteristics of.....	5-7
Measures to Safeguard.....	5-27
Statical Stability	
Curve	5-26
After Damage	5-27
Strength Members.....	5-8

Subject	Paragraph, Figure, Table, Number
T	
Tank Levels (Liquid Loading)	5-36
V	
Ventilating Blowers, Portable	6-28
Ventilation System	3-1
W	
Washdown System	6-21
Watertight Integrity	5-31
Wedges	7-14
Wooden Plugs	8-9

By Order of the Secretary of the Army:

CARL E. VUONO
General *United States Army*
Chief of Staff

Official:

WILLIAM J. MEEHAN, II
Brigadier General United States Army
The Adjutant General

DISTRIBUTION:

To be distributed in accordance with DA Form 12-25A, Unit and Direct Support and General Support Maintenance requirements for Landing Craft, Utility, LUC-1466, Type III.

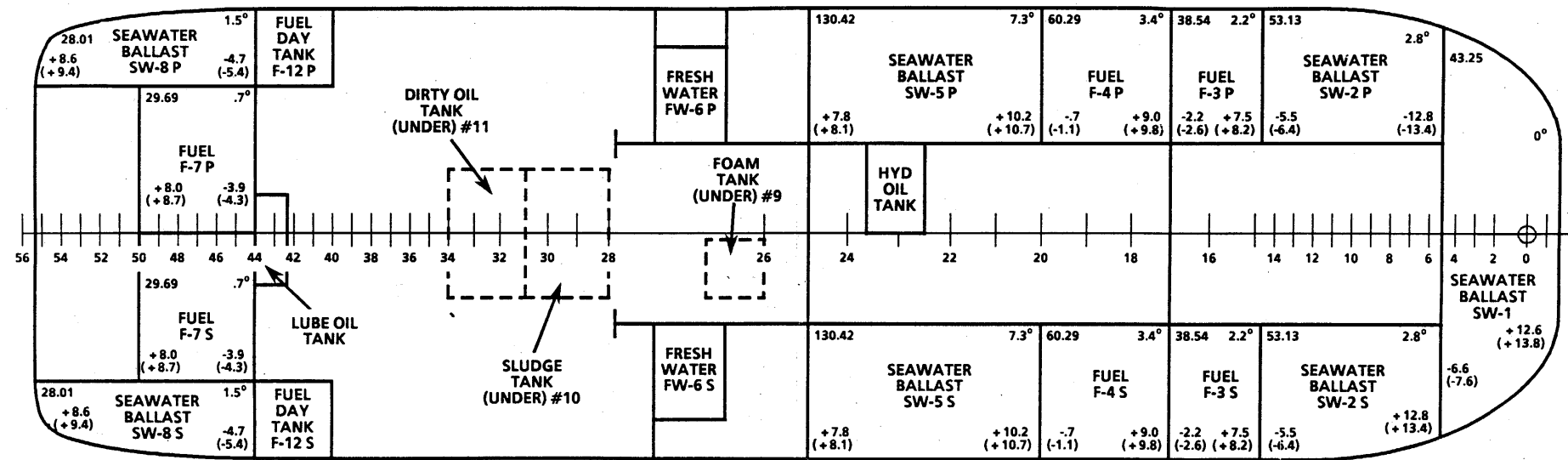

- A CAPACITY - TONS
- B LIST IN DEGREES
- C DRAFT CHANGE AFT - INCHES
- D DRAFT CHANGE FWD - INCHES
- (E) DRAFT CHANGE AFT - INCHES
- (F) DRAFT CHANGE FWD - INCHES

- FULL LOAD DEPARTURE
- FULL LOAD ARRIVAL

A	B
TANK NAME	
C	D
(E)	(F)

FO-1 (G-36A) 11/23/88

FO-1. Liquid Loading Diagram

FP-1 (FP-2 blank)

FP-1 (FP-2-blank)

129

RECOMMENDED CHANGES TO EQUIPMENT TECHNICAL PUBLICATIONS



*THEN...JOT DOWN THE
DOPE ABOUT IT ON THIS FORM.
CAREFULLY TEAR IT OUT, FOLD IT
AND DROP IT IN THE MAIL.*

SOMETHING WRONG WITH PUBLICATION

FROM: (PRINT YOUR UNIT'S COMPLETE ADDRESS)

DATE SENT

PUBLICATION NUMBER

PUBLICATION DATE

PUBLICATION TITLE

BE EXACT PIN-POINT WHERE IT IS

PAGE NO.	PARA-GRAPH	FIGURE NO.	TABLE NO.

IN THIS SPACE, TELL WHAT IS WRONG AND WHAT SHOULD BE DONE ABOUT IT.

PRINTED NAME, GRADE OR TITLE AND TELEPHONE NUMBER

SIGN HERE

TEAR ALONG PERFORATED LINE

The Metric System and Equivalents

Linear Measure

1 centimeter = 10 millimeters = .39 inch
 1 decimeter = 10 centimeters = 3.94 inches
 1 meter = 10 decimeters = 39.37 inches
 1 dekameter = 10 meters = 32.8 feet
 1 hectometer = 10 dekameters = 328.08 feet
 1 kilometer = 10 hectometers = 3,280.8 feet

Weights

1 centigram = 10 milligrams = .15 grain
 1 decigram = 10 centigrams = 1.54 grains
 1 gram = 10 decigrams = .035 ounce
 1 dekagram = 10 grams = .35 ounce
 1 hectogram = 10 dekagrams = 3.52 ounces
 1 kilogram = 10 hectograms = 2.2 pounds
 1 quintal = 100 kilograms = 220.46 pounds
 1 metric ton = 10 quintals = 1.1 short tons

Liquid Measure

1 centiliter = 10 milliliters = .34 fl. ounce
 1 deciliter = 10 centiliters = 3.38 fl. ounces
 1 liter = 10 deciliters = 33.81 fl. ounces
 1 dekaliter = 10 liters = 2.64 gallons
 1 hectoliter = 10 dekaliters = 26.42 gallons
 1 kiloliter = 10 hectoliters = 264.18 gallons

Square Measure

1 sq. centimeter = 100 sq. millimeters = .155 sq. inch
 1 sq. decimeter = 100 sq. centimeters = 15.5 sq. inches
 1 sq. meter (centare) = 100 sq. decimeters = 10.76 sq. feet
 1 sq. dekameter (are) = 100 sq. meters = 1,076.4 sq. feet
 1 sq. hectometer (hectare) = 100 sq. dekameters = 2.47 acres
 1 sq. kilometer = 100 sq. hectometers = .386 sq. mile

Cubic Measure

1 cu. centimeter = 1000 cu. millimeters = .06 cu. inch
 1 cu. decimeter = 1000 cu. centimeters = 61.02 cu. inches
 1 cu. meter = 1000 cu. decimeters = 35.31 cu. feet

Approximate Conversion Factors

To change	To	Multiply by	To change	To	Multiply by
inches	centimeters	2.540	ounce-inches	newton-meters	.007062
feet	meters	.305	centimeters	inches	.394
yards	meters	.914	meters	feet	3.280
miles	kilometers	1.609	meters	yards	1.094
square inches	square centimeters	6.451	kilometers	miles	.621
square feet	square meters	.093	square centimeters	square inches	.155
square yards	square meters	.836	square meters	square feet	10.764
square miles	square kilometers	2.590	square meters	square yards	1.196
acres	square hectometers	.405	square kilometers	square miles	.386
cubic feet	cubic meters	.028	square hectometers	acres	2.471
cubic yards	cubic meters	.765	cubic meters	cubic feet	35.315
fluid ounces	milliliters	29.573	cubic meters	cubic yards	1.308
pints	liters	.473	milliliters	fluid ounces	.034
quarts	liters	.946	liters	pints	2.113
gallons	liters	3.785	liters	quarts	1.057
ounces	grams	28.349	liters	gallons	.264
pounds	kilograms	.454	grams	ounces	.035
short tons	metric tons	.907	kilograms	pounds	2.205
pound-feet	newton-meters	1.356	metric tons	short tons	1.102
pound-inches	newton-meters	.11296			

Temperature (Exact)

°F	Fahrenheit temperature	5/9 (after subtracting 32)	Celsius temperature	°C
----	------------------------	----------------------------	---------------------	----

PIN: 064439-000